

DIMENSIONS

MODEL NO.	A	B	C	D	E	F	G	H	J	K	L
HS-2-2000	.44	6.00	.50	.50	5.00	3.00	1.25	7.50	4.00	.38	4.50
HS-2-4000	.56	6.00	.63	.75	5.00	3.00	1.25	7.50	4.00	.38	4.50
HS-2-6000	.69	7.50	.75	.75	6.00	4.00	2.00	9.50	5.00	.50	6.00
HS-2-8000	.94	10.50	1.00	1.00	6.00	4.00	2.00	13.50	5.00	.50	8.00

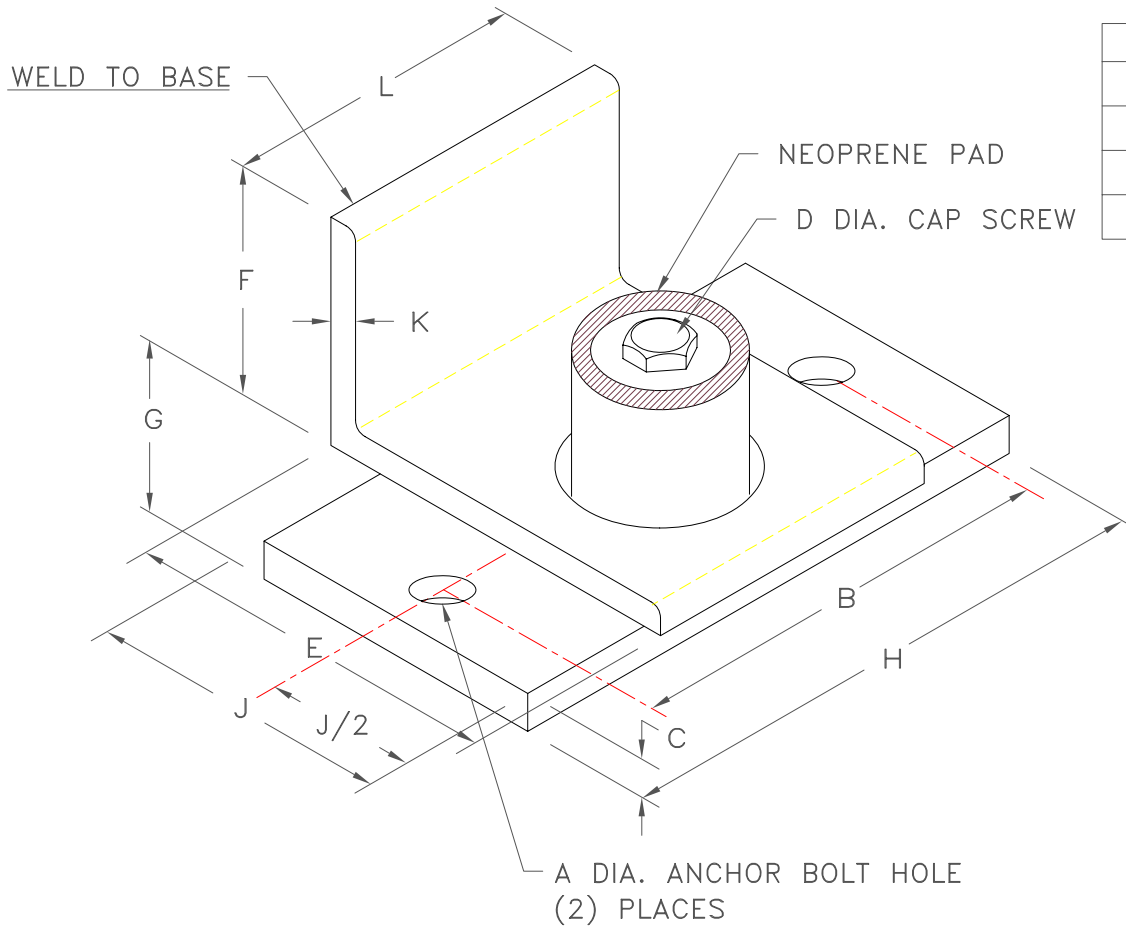

LOAD LIMIT VALUES	2000	4000	6000	8000
STANDARD ANCHORS	945#	1308#	1677#	3354#
ANCHORS 100% INSP.	1267#	1854#	2646#	5235#
BOLTED TO STEEL	1624#	2887#	4300#	6966#
WELDED TO STEEL	1779#	3387#	4922#	6966#

ANCHOR LOADS BASED ON ITW TRUBOLT WEDGE ANCHORS IN 3500 PSI STONE AGGREGATE CONCRETE

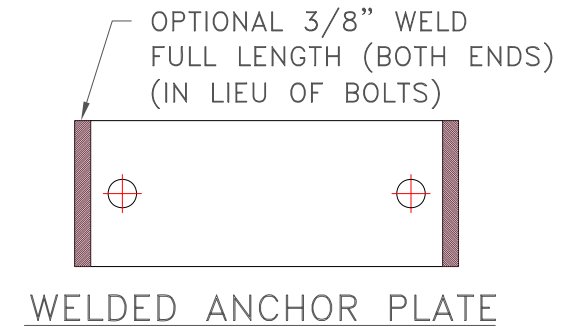

NOTE:
1. ALL DIMENSIONS IN INCHES.