

SRH 51 mm DEFLECTION ISOLATION HANGERS

S-I UNITS (mm AND kg)

TYPE	L	H	W	A	Dmax
2-260/1200	44	218	142	92	22

STANDARD RATINGS				SPRING COIL			INSERT
TYPE	SIZE	LOAD	DEFL.	COLOR	FREE HT.	O.D.	COLOR
SRH	2-260	118	56	BLUE	107	76	GREEN
SRH	2-465	211	51	GREEN	107	76	WHITE
SRH	2-720	327	53	BLACK	107	76	PURPLE
SRH	2-850	386	50	WHITE	108	76	YELLOW
SRH	2-1025	465	51	BEIGE	108	76	YELLOW
SRH	2-1200	544	51	CHROME	114	76	YELLOW

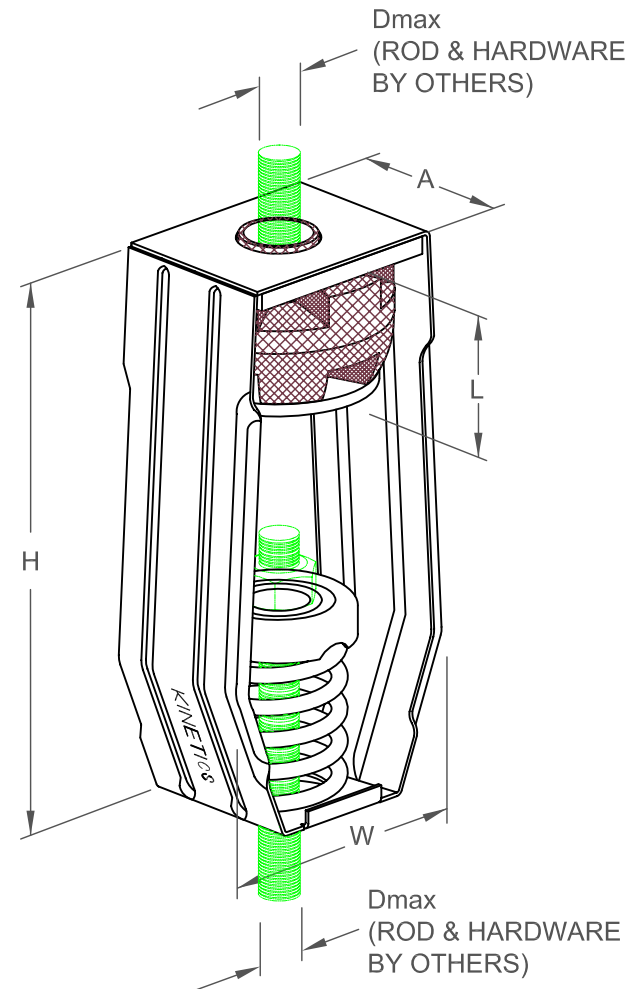

SPECIFICATIONS:

- SPRING ELEMENTS AND BRACKETS ARE POWDER COATED
- LOAD PLATES ARE BRIGHT ZINC PLATED
- ISOLATION HANGERS HAVE A MINIMUM K_x/K_y RATIO OF 1.1
- SPRING ELEMENTS ARE SAFE AT SOLID LOADING
- HANGER BRACKETS WILL CARRY (5) TIMES OVERLOAD WITHOUT FAILURE
- HANGER BRACKETS WILL ALLOW 30° ROD MISALIGNMENT WITHOUT SHORT CIRCUITING
- "NO SHORT" STEP CAP



KINETICS NOISE CONTROL, INC
 6300 IRELAN PL,
 DUBLIN, OH 43017 USA
 Ph: 614 889-0480, Fax: 614 889-0540
 www.kineticsnoise.com

Model:
 SRH
 2-260/1200

By: BB
 Date: 11/03/04
 Revised: /

Drawing No:
 S-03.37-22(M)