

SRH 51 mm DEFLECTION ISOLATION HANGERS

S-I UNITS (mm AND kg)

TYPE	L	H	W	A	Dmax
2-35/220	44	187	94	57	13

STANDARD RATINGS				SPRING COIL			INSERT COLOR
TYPE	SIZE	LOAD	DEFL.	COLOR	FREE HT.	O.D.	
SRH	2-35	16	53	BLUE	105	44	BLACK
SRH	2-70	32	56	GREEN	105	44	BLACK
SRH	2-120	54	59	GRAY	105	44	BLACK
SRH	2-220	100	58	BROWN	105	44	GREEN

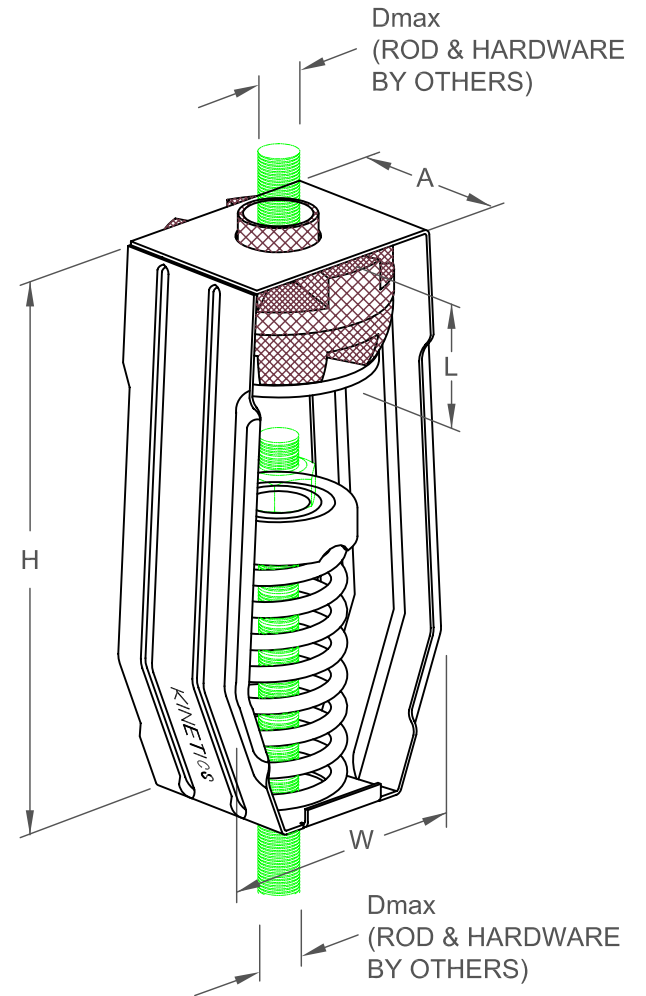

SPECIFICATIONS:

- SPRING ELEMENTS AND BRACKETS ARE POWDER COATED
- LOAD PLATES ARE BRIGHT ZINC PLATED
- ISOLATION HANGERS HAVE A MINIMUM Kx/Ky RATIO OF 1.1
- SPRING ELEMENTS ARE SAFE AT SOLID LOADING
- HANGER BRACKETS WILL CARRY (5) TIMES OVERLOAD WITHOUT FAILURE
- HANGER BRACKETS WILL ALLOW 30° ROD MISALIGNMENT WITHOUT SHORT CIRCUITING
- "NO SHORT" STEP CAP



KINETICS NOISE CONTROL, INC
6300 IRELAN PL,
DUBLIN, OH 43017 USA
Ph: 614 889-0480, Fax: 614 889-0540
www.kineticsnoise.com

Model:
SRH
2-35/220

By: **JMJ**
Date: **02/26/03**
Revised: **/**

Drawing No:
S-03.37-21(M)