

# SRH 102 mm DEFLECTION ISOLATION HANGERS

S-I UNITS (mm AND kg)

TYPE	H	W	A	DMAX
4-100/1600	406	238	152	22

STANDARD RATINGS				SPRING COIL		
TYPE	SIZE	LOAD	DEFL.	COLOR	FREE HT.	O.D.
SH	4-100	45	102	GRAY	254	143
SH	4-250	113	102	BLUE	254	143
SH	4-500	227	102	GREEN	254	143
SH	4-750	340	102	BLACK	254	143
SH	4-1000	454	102	RED	254	143
SH	4-1250	567	102	BROWN	254	143
SH	4-1600	726	102	ORANGE	254	143

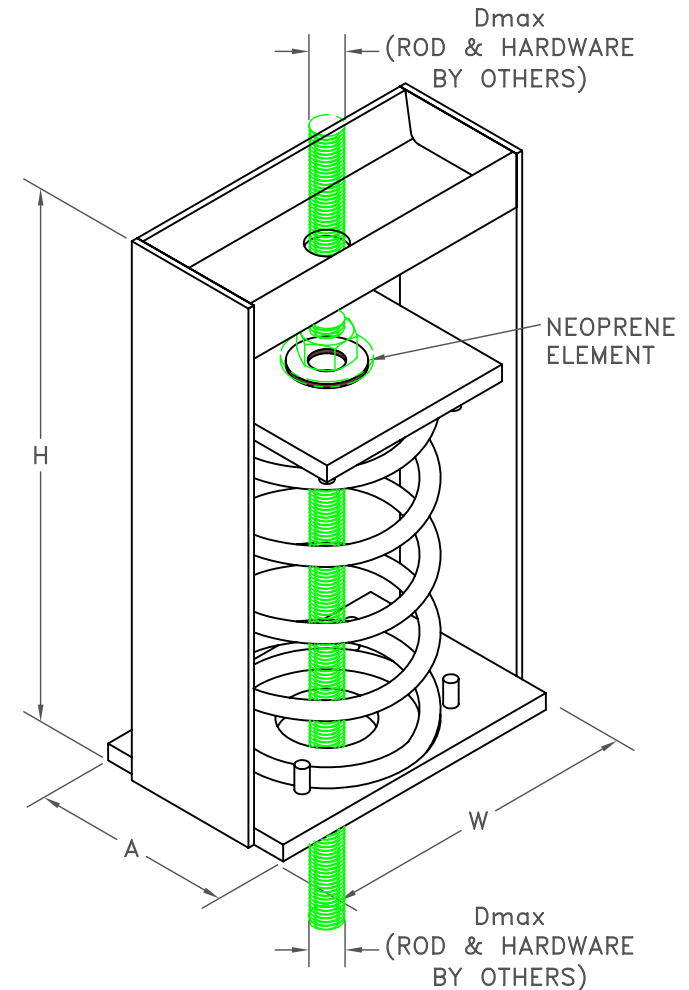

## SPECIFICATIONS:

- SPRING ELEMENTS ARE POWDER COATED.
- BRACKETS AND LOAD PLATES ARE PAINTED.
- ISOLATION HANGERS HAVE A TYPICAL OVERLOAD OF 50%.
- ISOLATION HANGERS HAVE A MINIMUM  $K_x/K_y$  RATIO OF 1.0.
- SPRING ELEMENTS ARE SAFE AT SOLID LOADING.
- HANGER BRACKETS WILL CARRY (5) TIMES OVERLOAD WITHOUT FAILURE.
- HANGER BRACKETS WILL ALLOW 30° ROD MISALIGNMENT WITHOUT SHORT CIRCUITING.

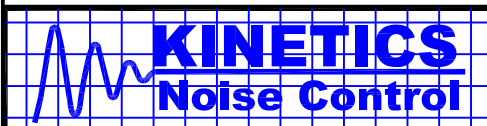

KINETICS NOISE CONTROL, INC  
 6300 IRELAN PL,  
 DUBLIN, OH 43017 USA  
 Ph: 614 889-0480, Fax: 614 889-0540  
 www.kineticsnoise.com

Model:  
 SH  
 4-100/1600

By: BB  
 Date: 12/07/05  
 Revised: /

Drawing No:  
 S-03.36-41  
 METRIC