

SH 51 mm DEFLECTION ISOLATION HANGERS

S-I UNITS (mm AND kg)

TYPE	L	H	W	A	DMAX
2-260/1200	51	218	142	92	22

STANDARD RATINGS				SPRING COIL			INSERT COLOR
TYPE	SIZE	LOAD	DEFL.	COLOR	FREE HT.	O.D.	
SH	2-260	118	56	BLUE	107	76	GREEN
SH	2-465	211	51	GREEN	107	76	WHITE
SH	2-720	327	53	BLACK	107	76	PURPLE
SH	2-850	386	50	WHITE	108	76	YELLOW
SH	2-1025	465	51	BEIGE	108	76	YELLOW
SH	2-1200	544	51	CHROME	114	76	YELLOW

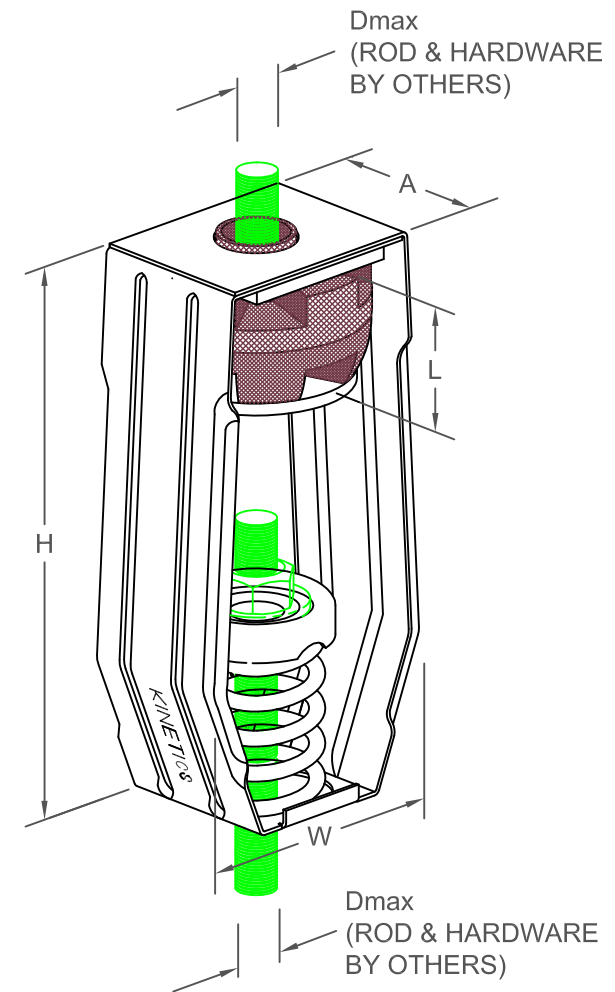

SPECIFICATIONS:

- SPRING ELEMENTS AND BRACKETS ARE POWDER COATED.
- LOAD PLATES ARE BRIGHT ZINC PLATED.
- ISOLATION HANGERS HAVE A TYPICAL OVERLOAD OF 50%.
- ISOLATION HANGERS HAVE A MINIMUM K_x/K_y RATIO OF 1.0.
- SPRING ELEMENTS ARE SAFE AT SOLID LOADING.
- HANGER BRACKETS WILL CARRY (5) TIMES OVERLOAD WITHOUT FAILURE.
- HANGER BRACKETS WILL ALLOW 30° ROD MISALIGNMENT WITHOUT SHORT CIRCUITING.
- HANGER INCORPORATES "NO SHORT" STEP CAP.



KINETICS NOISE CONTROL, INC
 6300 IRELAN PL,
 DUBLIN, OH 43017 USA
 Ph: 614 889-0480, Fax: 614 889-0540
 www.kineticsnoise.com

Model:
 SH
 2-260/1200

By: BB
 Date: 12/07/05
 Revised: 12/10/09 / BB

Drawing No:
 S-03.36-22
 METRIC