

SH 25 mm DEFLECTION ISOLATION HANGERS

S-I UNITS (mm AND kg)

TYPE	H	W	A	DMAX
1-35/370	133	94	57	16
1-500/600	133	94	57	16
1-700/805	133	94	57	16

STANDARD RATINGS				SPRING COIL			
TYPE	SIZE	LOAD	DEFL.	COLOR		FREE	
				OUTER	INNER	HT.	O.D.
SH	1-35	16	39	BLUE		81	44
SH	1-70	32	35	GREEN		81	44
SH	1-125	57	31	GRAY		81	44
SH	1-245	111	30	BROWN		81	44
SH	1-370	168	24	ORANGE		81	44
SH	1-500	227	25	BEIGE		81	44
SH	1-600	272	25	CHROME		81	44
SH	1-700	318	25	BEIGE	WHITE	81	44
SH	1-805	365	26	CHROME	WHITE	81	44

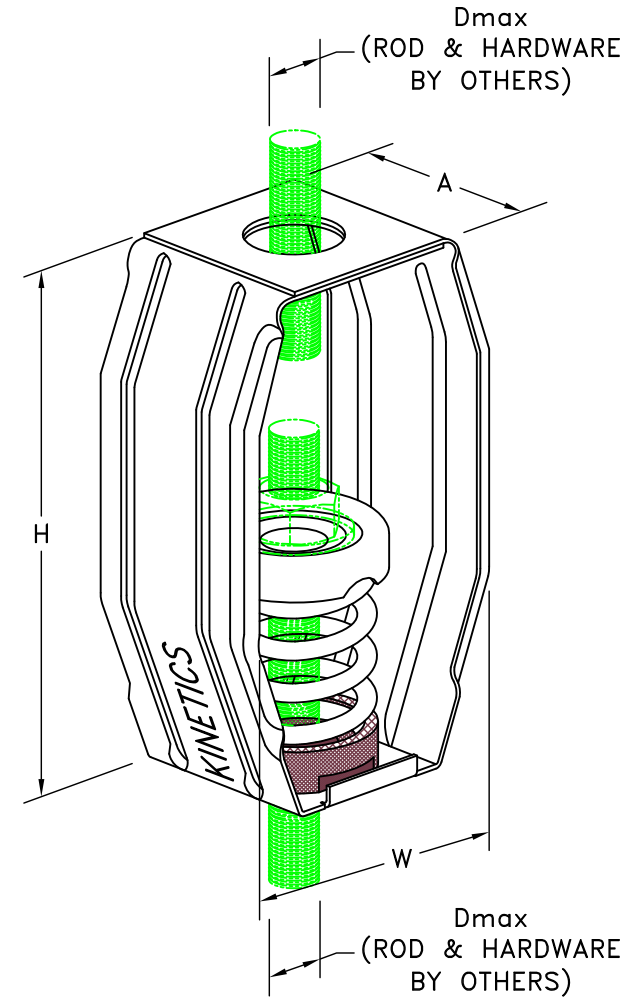

SPECIFICATIONS:

- SPRING ELEMENTS AND BRACKETS ARE POWDER COATED.
- LOAD PLATES ARE BRIGHT ZINC PLATED.
- ISOLATION HANGERS HAVE A TYPICAL OVERLOAD OF 50%.
- ISOLATION HANGERS HAVE A MINIMUM K_x/K_y RATIO OF 1.0.
- SPRING ELEMENTS ARE SAFE AT SOLID LOADING.
- HANGER BRACKETS WILL CARRY (5) TIMES OVERLOAD WITHOUT FAILURE.
- HANGER BRACKETS WILL ALLOW 30° ROD MISALIGNMENT WITHOUT SHORT CIRCUITING, EXCEPT AS NOTED (*).
- "NO SHORT" STEP CAP.



KINETICS NOISE CONTROL, INC
 6300 IRELAN PL.,
 DUBLIN, OH 43017 USA
 Ph: 614 889-0480, Fax: 614 889-0540
 www.kineticsnoise.com

Model:
 SH-1-
 35/805

By: B. LIVELY
 Date: 12/07/05
 Revised: 06/10/10 / BB

Drawing No:
 S-03.36-11
 METRIC