

SLI 1" DEFLECTION ISOLATOR

IP UNITS (INCHES AND POUNDS)

TYPE	A	B	C	E	F	G	H	L	W
35A/805A	5.63	1.06	0.31	-	-	-	4.05	6.13	2.13
50C/3500C	8.00	1.75	0.44	2.00	7.50	0.44	5.55	9.00	3.50

NOTE: ALL MOUNTING DIMENSIONS SYMMETRIC ABOUT ISOLATOR CENTER

STANDARD RATINGS		SPRING COIL					
		COLOR		FREE		RATED	
TYPE	SIZE	OUTER	INNER	HT.	O.D.	LOAD	DEFL.
SLI	35A	BLUE		3.19	1.75	35	1.52
SLI	70A	GREEN		3.19	1.75	70	1.36
SLI	120A	GRAY		3.19	1.75	120	1.18
SLI	220A	BROWN		3.19	1.75	220	1.07
SLI	370A	ORANGE		3.19	1.75	370	0.96
SLI	500A	BEIGE		3.19	1.75	500	1.00
SLI	600A	CHROME		3.19	1.75	600	1.00
SLI	700A	BEIGE	WHITE	3.19	1.75	700	1.00
SLI	805A	CHROME	WHITE	3.19	1.75	805	1.01
SLI	50C	BEIGE		4.20	3.00	50	1.00
SLI	100C	CHROME		4.20	3.00	100	1.00
SLI	250C	BLUE		4.20	3.00	250	1.79
SLI	450C	GREEN		4.20	3.00	450	1.54
SLI	625C	BLACK		4.20	3.00	625	1.44
SLI	800C	GRAY		4.20	3.00	800	1.31
SLI	1000C	RED		4.20	3.00	1000	1.15
SLI	1250C	BROWN		4.20	3.00	1250	1.09
SLI	1700C	ORANGE		4.20	3.00	1700	0.95
SLI	2200C	ORANGE	GRAY	4.20	3.00	2200	1.00
SLI	2465C	BLUE		4.20	3.00	2465	1.00
SLI	2865C	BLUE	GRAY	4.20	3.00	2865	1.00
SLI	3500C	BLUE	BROWN	4.20	3.00	3500	1.00

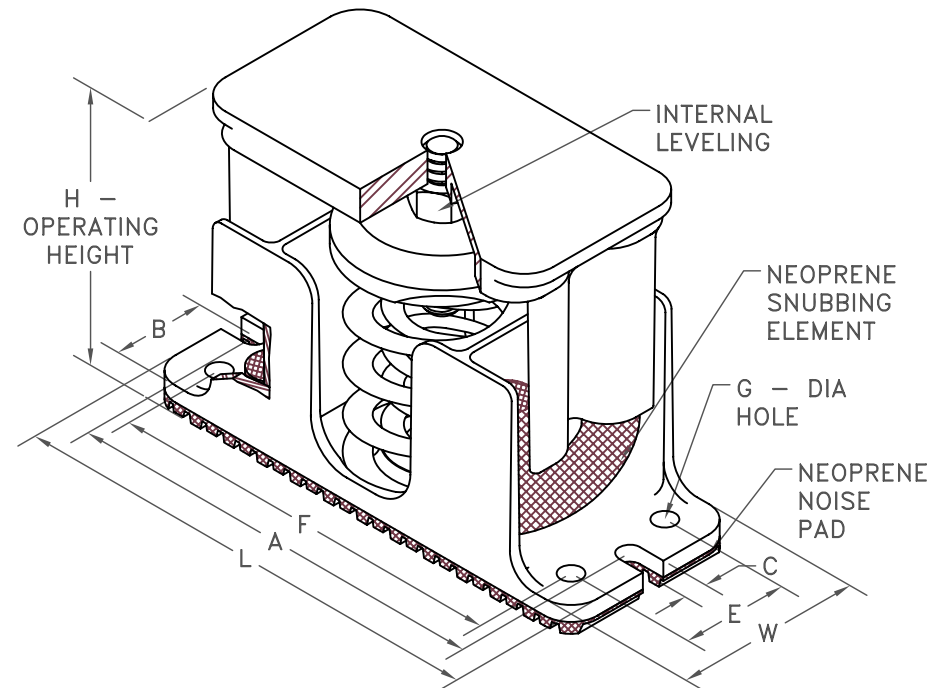

SPECIFICATIONS:

- HOUSED COIL SPRING ISOLATOR WITH INTERNAL SNUBBERS.
- POWDER COATED STEEL SPRING ELEMENTS.
- OTHER METALLIC HARDWARE IS BRIGHT ZINC PLATED.
- 35A/805A HOUSINGS ARE CAST ALUMINUM, 50C/3500C ARE CAST IRON.
- MINIMUM OVERLOAD OF 50%.
- MINIMUM Kx/Ky RATIO OF 1.0.
- ALL ELEMENTS SAFE AT SOLID LOADING.
- ALL THREADED MEMBERS ARE AMERICAN STANDARD.



KINETICS NOISE CONTROL, INC
 6300 IRELAN PL,
 DUBLIN, OH 43017 USA
 Ph: 614 889-0480, Fax: 614 889-0540
 www.kineticsnoise.com

Model:
SLI-35A/3500C

By: BB
 Date: 02/11/08
 Revised: /

Drawing No:
S-01.26-11