

### FLSS 1" DEFLECTION ISOLATOR

IP UNITS (INCHES AND POUNDS)

TYPE	L	W	T	A	B	D	E	F	d	H	TT
1-2500/7000	15.25	5.00	0.38	0.75	0.75	0.69	2.75	2.75	0.56	6.88	0.63

\*ALL MOUNTING BOLT PATTERNS SYMMETRICAL ABOUT ISOLATOR CENTER-LINE

STANDARD RATINGS		SPRING COIL					
TYPE	SIZE	COLOR		FREE		RATED	
		OUTER	INNER	HT.	O.D.	LOAD	DEFL.
FLSS	1-2500	BROWN		4.20	3.00	2500	1.09
FLSS	1-3400	ORANGE		4.20	3.00	3400	0.95
FLSS	1-4400	ORANGE	GRAY	4.20	3.00	4400	1.00
FLSS	1-4930	BLUE		4.20	3.00	4930	1.00
FLSS	1-5730	BLUE	GRAY	4.20	3.00	5730	1.00
FLSS	1-7000	BLUE	BROWN	4.20	3.00	7000	1.00

1-2500/7000 REQUIRES 0.62 DIA. x 4.00 MIN. EMBED ANCHORS IN CONCRETE

(ALLOWABLE LOADS BASED ON 3000 PSI MIN CONCRETE)

1-2500/7000 ANCHOR BOLT TORQUE - 75 FT-LB, PULL TEST - 2670 LB

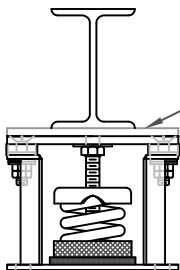
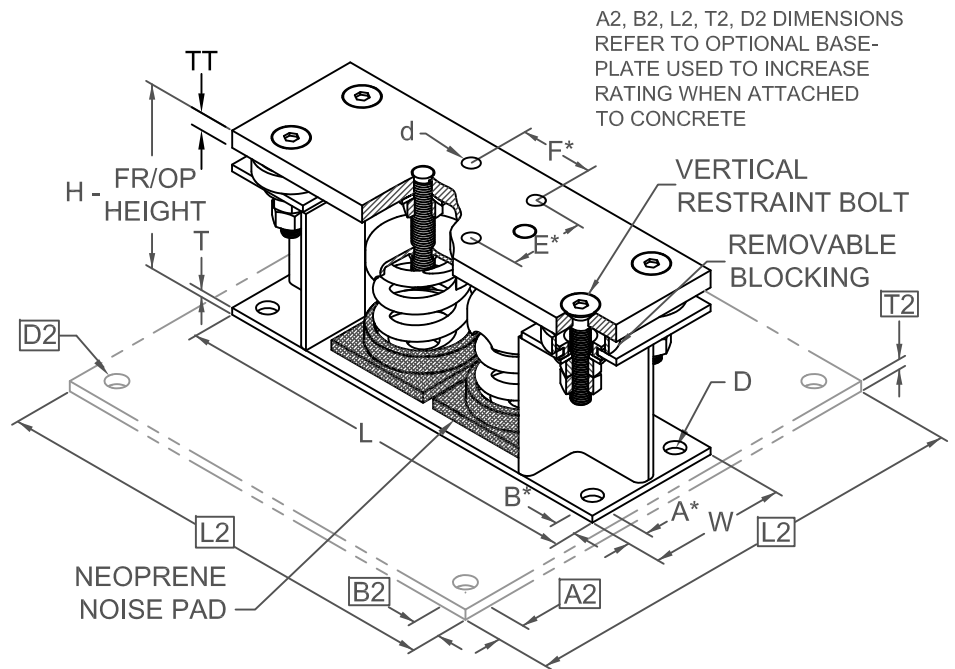

IF EQUIP SUPPORT STEEL IS 90° TO THE LONG ISOLATOR AXIS, AN ADD'L PLATE EQUAL IN THICKNESS TO THE TOP PLATE IS REQUIRED

#### SPECIFICATIONS:

- VERTICALLY AND LATERALLY RESTRAINED SPRING ISOLATOR WITH CONSTANT FREE AND OPERATING HEIGHT AND REPLACEABLE NEOPRENE SNUBBING ELEMENTS.
- WHEN PROPERLY ADJUSTED, MAX. CLEARANCE IN SNUBBING ELEMENTS IS LIMITED TO 0.25 INCHES.
- MINIMUM COIL OVERLOAD OF 50%.
- MINIMUM Kx/Ky RATIO OF 1.0.
- ALL ELEMENTS SAFE AT SOLID LOADING.
- POWDER COATED COILS AND HOT DIPPED GALVANIZED BRACKET.
- HOUSINGS MAY BE USED FOR BLOCKING DURING EQUIPMENT ERECTION.

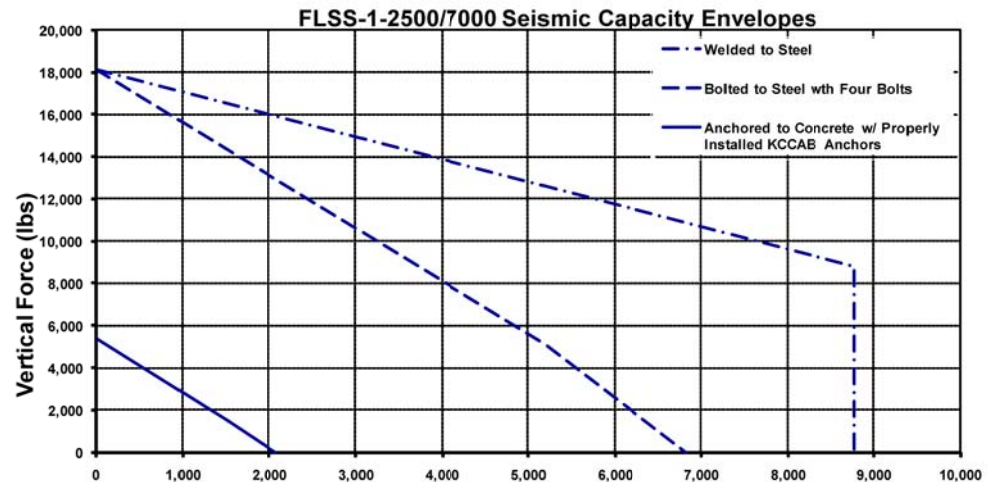

Computed horizontal and vertical seismic load combinations must fall within the restraint capacity envelope



KINETICS NOISE CONTROL, INC  
6300 IRELAN PL,  
DUBLIN, OH 43017 USA  
Ph: 614 889-0480, Fax: 614 889-0540  
www.kineticsnoise.com

Model:  
FLSS-1-  
2500/7000

By: JMJ  
Date: 07/12/02  
Revised: 09/17/10 / BB

Drawing No:  
S-01.22-12S