

FLS 102 mm DEFLECTION ISOLATOR

S-I UNITS (mm AND kg)

TYPE	L	W	T	A	B	D	E	F	d	H	TT
4-11000/23200	686	432	19	25	25	21	140	140	17	381	19

*ALL MOUNTING BOLT PATTERNS SYMMETRICAL ABOUT ISOLATOR CENTER-LINE

STANDARD RATINGS		SPRING COIL					
TYPE	SIZE	COLOR		FREE		RATED	
		OUTER	INNER	HT.	O.D.	LOAD	DEFL.
FLS	4-11000	BEIGE	GREEN	292	203	4990	102
FLS	4-12000	BEIGE	BLACK	292	203	5443	102
FLS	4-13000	BEIGE	RED	292	203	5897	102
FLS	4-14000	BEIGE	BROWN	292	203	6350	102
FLS	4-15400	BEIGE	ORANGE	292	203	6985	102
FLS	4-16800	CHROME		292	203	7620	102
FLS	4-17800	CHROME	BLUE	292	203	8074	102
FLS	4-18800	CHROME	GREEN	292	203	8528	102
FLS	4-19800	CHROME	BLACK	292	203	8981	102
FLS	4-20800	CHROME	RED	292	203	9435	102
FLS	4-21800	CHROME	BROWN	292	203	9888	102
FLS	4-23200	CHROME	ORANGE	292	203	10523	102

4-11000/23200 REQUIRES 019 DIA. x 119 MIN. EMBED ANCHORS IN CONCRETE

(ALLOWABLE LOADS BASED ON 21 MPa MIN CONCRETE)

4-11000/23200 ANCHOR BOLT TORQUE - 203 N-M, PULL TEST - 1644 kg

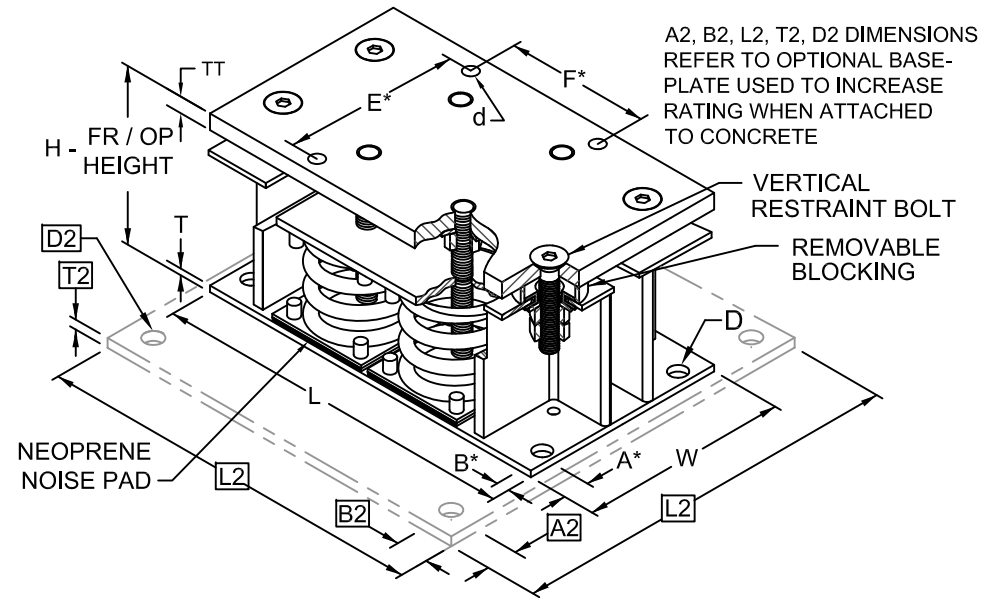

A2, B2, L2, T2, D2 DIMENSIONS REFER TO OPTIONAL BASE-PLATE USED TO INCREASE RATING WHEN ATTACHED TO CONCRETE

VERTICAL RESTRAINT BOLT
REMOVABLE BLOCKING

NEOPRENE NOISE PAD

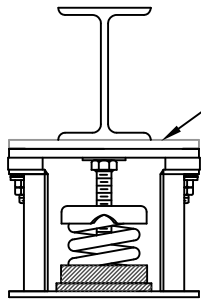

IF EQUIP SUPPORT STEEL IS 90° TO THE LONG ISOLATOR AXIS, AN ADD'L PLATE EQUAL IN THICKNESS TO THE TOP PLATE IS REQUIRED

SPECIFICATIONS:

- VERTICALLY AND Laterally RESTRAINED SPRING ISOLATOR WITH CONSTANT FREE AND OPERATING HEIGHT AND REPLACEABLE NEOPRENE SNUBBING ELEMENTS.
- WHEN PROPERLY ADJUSTED, MAX. CLEARANCE IN SNUBBING ELEMENTS IS LIMITED TO 0.25 INCHES.
- MINIMUM COIL OVERLOAD OF 50%.
- MINIMUM Kx/Ky RATIO OF 1.0.
- ALL ELEMENTS SAFE AT SOLID LOADING.
- POWDER COATED COILS AND HOT DIPPED GALVANIZED BRACKET.
- HOUSINGS MAY BE USED FOR BLOCKING DURING EQUIPMENT ERECTION.

FLS-4-11000/23200 Seismic Capacity Envelopes

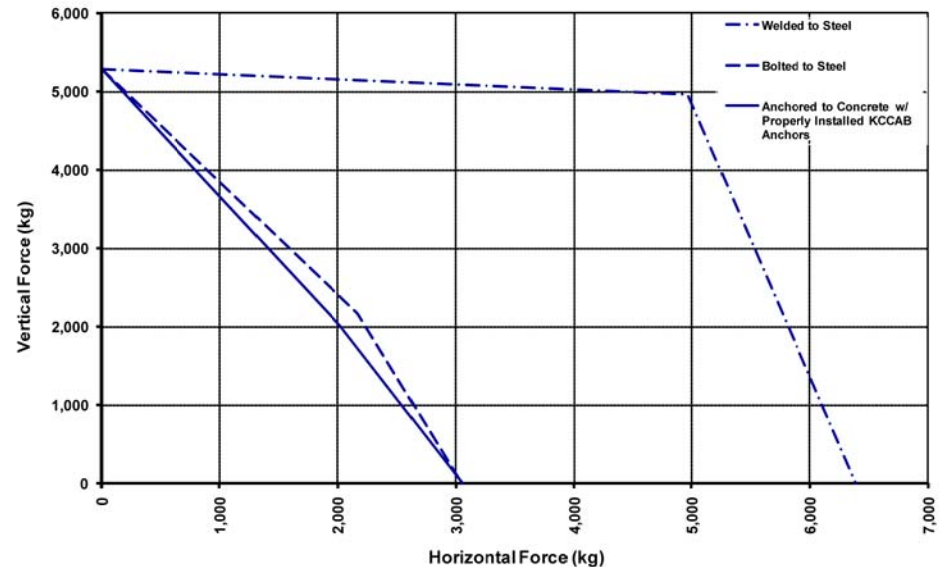

Computed horiz. and vert. seismic load combinations must fall within the restraint capacity envelope.



KINETICS NOISE CONTROL, INC
6300 IRELAN PL,
DUBLIN, OH 43017 USA
Ph: 614 889-0480, Fax: 614 889-0540
www.kineticsnoise.com

Model:
FLS-4-
11000/23200

By: JMJ
Date: 07/09/02
Revised: 05/10/10 / BB

Drawing No:
S-01.22-44
METRIC