

FLS 2" DEFLECTION ISOLATOR

IP UNITS (INCHES AND POUNDS)

TYPE	L	W	T	A	B	D	E	F	d	H	TT
2-4000/9000	17.50	6.00	0.38	1.25	1.00	0.69	2.75	2.75	0.56	10.00	0.63

*ALL MOUNTING BOLT PATTERNS SYMMETRICAL ABOUT ISOLATOR CENTER-LINE

STANDARD RATINGS		SPRING COIL						
TYPE	SIZE	COLOR		FREE		RATED		
		OUTER	INNER1	INNER2	HT.	O.D.	LOAD	DEFL.
FLS	2-4000	ORANGE			7.00	5.00	4000	2.00
FLS	2-5000	BLUE			7.00	5.00	5000	2.00
FLS	2-5500	BLUE	BLUE		7.00	5.00	5500	2.00
FLS	2-6050	BLUE	GREEN		7.00	5.00	6050	2.02
FLS	2-6500	BLUE	BLACK		7.00	5.00	6500	2.00
FLS	2-7000	BLUE	ORANGE		7.00	5.00	7000	2.00
FLS	2-7800	BLUE	ORANGE	GREEN	7.00	5.00	7800	2.00
FLS	2-8200	BLUE	RED		7.00	5.00	8200	2.00
FLS	2-9000	BLUE	RED	GREEN	7.00	5.00	9000	2.00

2-4000/9000 REQUIRES 0.62 DIA. x 4.00 MIN. EMBED ANCHORS IN CONCRETE

(ALLOWABLE LOADS BASED ON 3000 PSI MIN CONCRETE)

2-4000/9000 ANCHOR BOLT TORQUE - 75 FT-LB, PULL TEST - 2670 LB

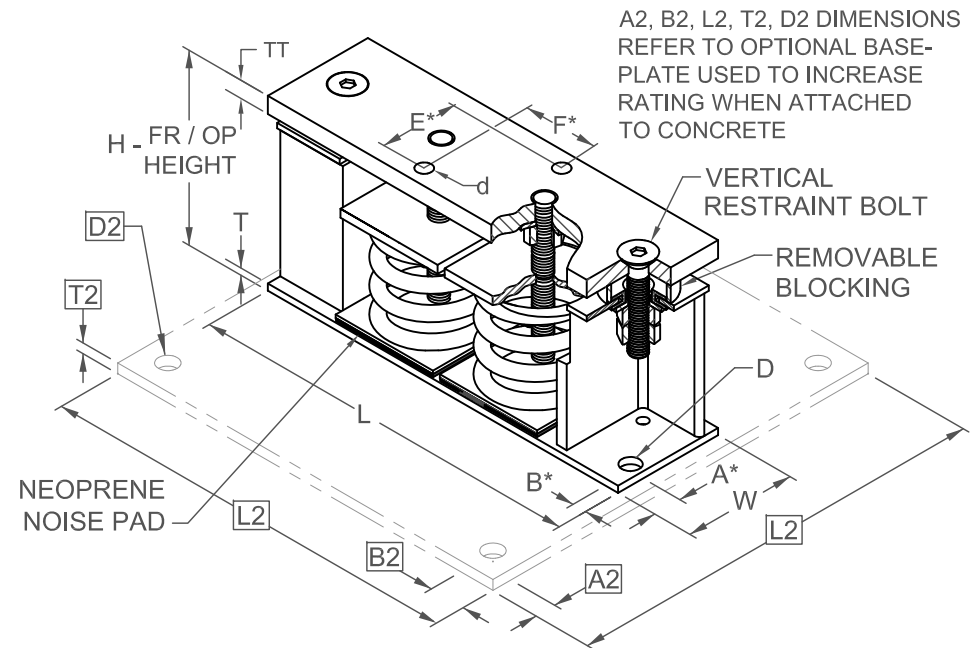

A2, B2, L2, T2, D2 DIMENSIONS REFER TO OPTIONAL BASE-PLATE USED TO INCREASE RATING WHEN ATTACHED TO CONCRETE

FLS-2-4000/9000 Seismic Capacity Envelopes

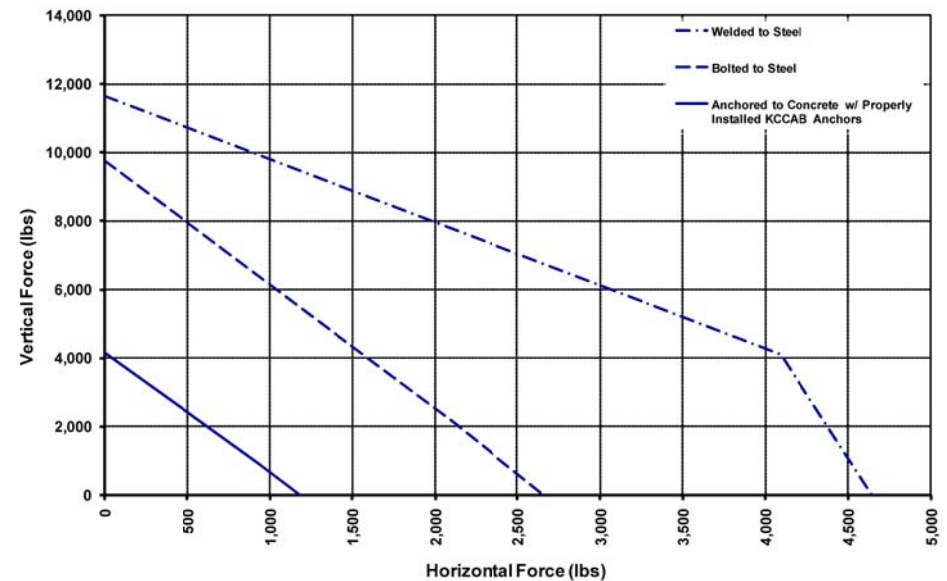

Computed horiz. and vert. seismic load combinations must fall within the restraint capacity envelope.

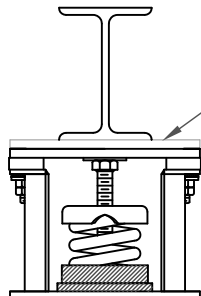

IF EQUIP SUPPORT STEEL IS 90° TO THE LONG ISOLATOR AXIS, AN ADD'L PLATE EQUAL IN THICKNESS TO THE TOP PLATE IS REQUIRED

SPECIFICATIONS:

- VERTICALLY AND Laterally RESTRAINED SPRING ISOLATOR WITH CONSTANT FREE AND OPERATING HEIGHT AND REPLACEABLE NEOPRENE SNUBBING ELEMENTS.
- WHEN PROPERLY ADJUSTED, MAX. CLEARANCE IN SNUBBING ELEMENTS IS LIMITED TO 0.25 INCHES.
- MINIMUM COIL OVERLOAD OF 50%.
- MINIMUM Kx/Ky RATIO OF 1.0.
- ALL ELEMENTS SAFE AT SOLID LOADING.
- POWDER COATED COILS AND HOT DIPPED GALVANIZED BRACKET.
- HOUSINGS MAY BE USED FOR BLOCKING DURING EQUIPMENT ERECTION.



KINETICS NOISE CONTROL, INC
6300 IRELAN PL,
DUBLIN, OH 43017 USA
Ph: 614 889-0480, Fax: 614 889-0540
www.kineticsnoise.com

Model:
FLS-2-
4000/9000

By: JMJ
Date: 07/09/02
Revised: 05/10/10 / BB

Drawing No:
S-01.22-23