

1 Deflection – Single “C” Coil Set – 250 lbs to 3,500 lbs

ISOLATOR MODEL	USED WITH FMS MODELS	RATED LOAD (LBS)	DEFLECTION @ RATED LOAD (IN)	SPRING RATE (LBS/IN)	SPRING COLOR OUTER/INNER	LOAD @ 1 IN. DEFLECTION (LBS)
1-250	A/B/C/D/E	250	1.79	139.7	Blue/-----	140
1-450	A/B/C/D/E	450	1.54	292.2	Green/-----	292
1-625	A/B/C/D/E	625	1.44	434.0	Black/-----	434
1-800	A/B/C/D/E	800	1.31	610.7	Gray/-----	611
1-1000	A/B/C/D/E	1,000	1.15	869.6	Red/-----	870
1-1250	A/B/C/D/E	1,250	1.09	1,146.8	Brown/-----	1,147
1-1700	A/B/C/D/E	1,700	0.95	1,789.5	Orange/-----	1,790
1-2100	A/B/C/D/E	2,080	0.95	2,189.5	Orange/Gray	2,190
1-2465	A/B/C/D/E	2,465	1.00	2,465.0	Blue/-----	2,465
1-2865	A/B/C/D/E	2,865	1.00	2,865.0	Blue/Gray	2,865
1-3500	A/B/C/D/E	3,500	1.00	3,500.0	Blue/Brown	3,500

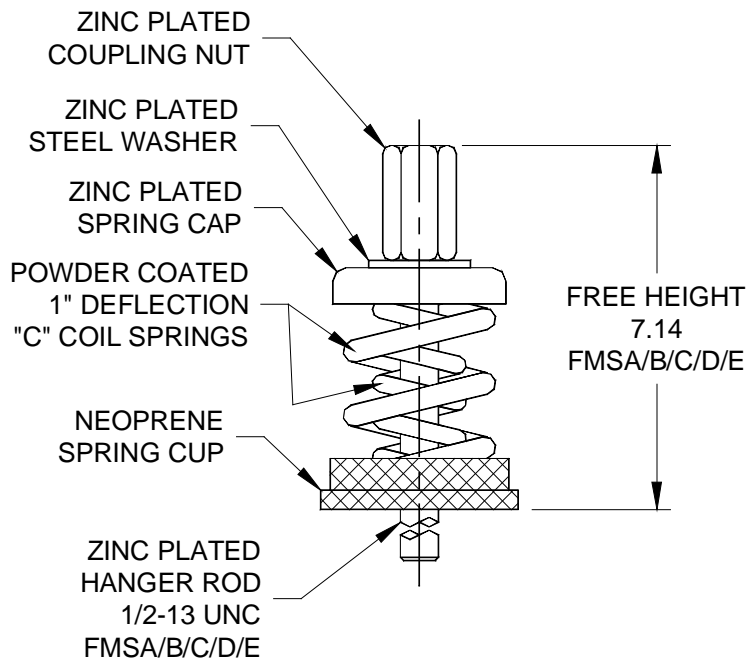

1 DEFLECTION – SINGLE “C” COIL ISOLATION SUBMITTAL DATA

PAGE 1 OF 4

RELEASE DATE: 5/6/04



Toll Free (USA only): 800-959-1229
 International: 614-889-0480
 Fax: 614-889-0540
 World Wide Web: www.kineticsnoise.com
 Email: sales@kineticsnoise.com

DOCUMENT:
P2.3.2
 VISCMA MEMBER

1 Deflection – Double “C” Coil Sets – 3,400 lbs to 7,000 lbs

ISOLATOR MODEL	USED WITH FMS MODELS	RATED LOAD (LBS)	DEFLECTION @ RATED LOAD (IN)	SPRING RATE (LBS/IN)	SPRING COLOR OUTER/INNER	LOAD @ 1 IN. DEFLECTION (LBS)
1-3400	C/D/E/F/G	3,400	0.95	3,579.0	Orange/-----	3,579
1-4200	C/D/E/F/G	4,160	0.95	4,379.0	Orange/Gray	4,379
1-4930	C/D/E/F/G	4,930	1.00	4,930.0	Blue/-----	4,930
1-5730	C/D/E/F/G	5,730	1.00	5,370.0	Blue/Gray	5,730
1-7000	--/D/E/F/G	7,000	1.00	7,000.0	Blue/Brown	7,000

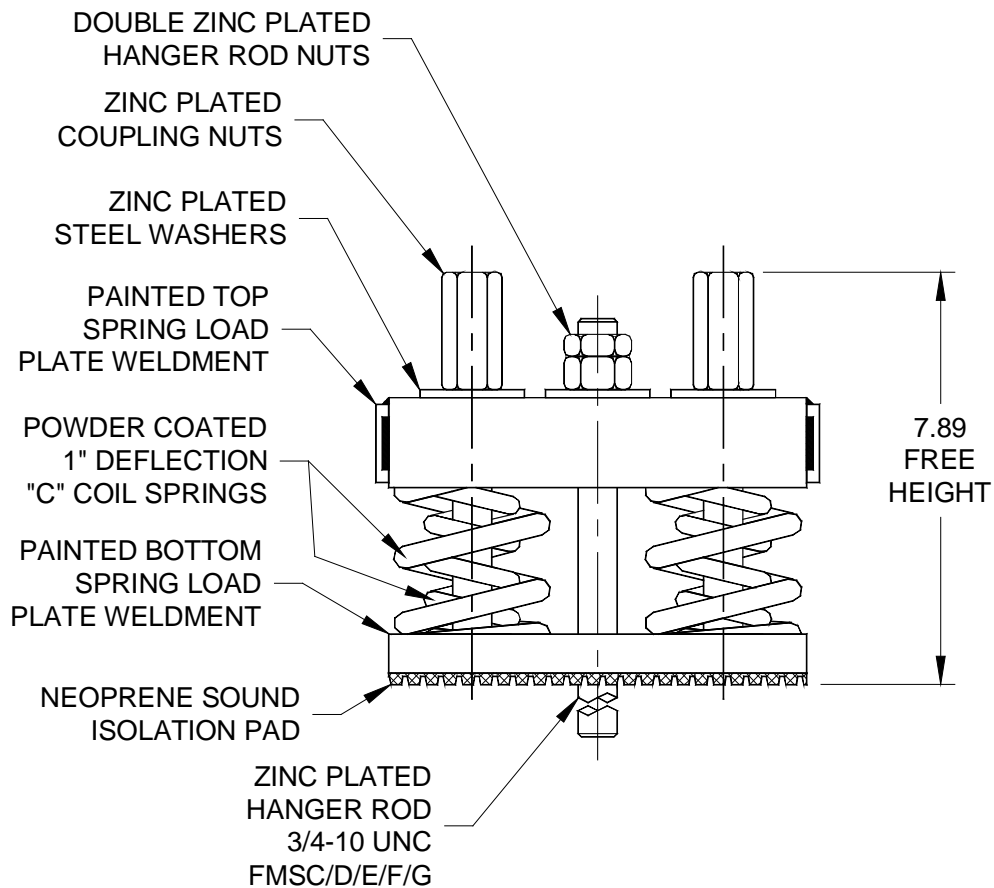

1” DEFLECTION – DOUBLE “C” COIL ISOLATION SUBMITTAL DATA

PAGE 2 OF 4

RELEASE DATE: 5/6/04



DUBLIN, OHIO, USA • MISSISSAUGA, ONTARIO, CANADA

Toll Free (USA only): 800-959-1229
 International: 614-889-0480
 Fax: 614-889-0540
 World Wide Web: www.kineticsnoise.com
 Email: sales@kineticsnoise.com

DOCUMENT:
P2.3.2
 VISCMA
 MEMBER

1 Deflection – Triple “C” Coil Sets – 3,750 lbs to 10,500 lbs

ISOLATOR MODEL	USED WITH FMS MODELS	RATED LOAD (LBS)	DEFLECTION @ RATED LOAD (IN)	SPRING RATE (LBS/IN)	SPRING COLOR OUTER/INNER	LOAD @ 1 IN. DEFLECTION (LBS)
1-3750	C/D/E/F/G	3,750	1.09	3,440.4	Brown/-----	3,440
1-5100	C/D/E/F/G	5,100	0.95	5,368.5	Orange/-----	5,369
†1-5900	C/D/E/F/G	5,860	0.95	6,168.5	Orange/Gray	6,169
‡1-6300	C/D/E/F/G	6,240	0.95	6,568.5	Orange/Gray	6,569
1-7395	--/D/E/F/G	7,395	1.00	7,395.0	Blue/-----	7,395
†1-8195	--/D/E/F/G	8,195	1.00	8,195.0	Blue/Gray	8,195
‡1-8595	--/D/E/F/G	8,595	1.00	8,595.0	Blue/Gray	8,595
†1-9500	--/D/E/F/G	9,465	1.00	9,465.0	Blue/Brown	9,465
‡1-10500	--/--/E/F/G	10,500	1.00	10,500.0	Blue/Brown	10,500

†Center coil set does not contain an inner coil.

‡Center coil set contains an inner coil and requires a special load washer.

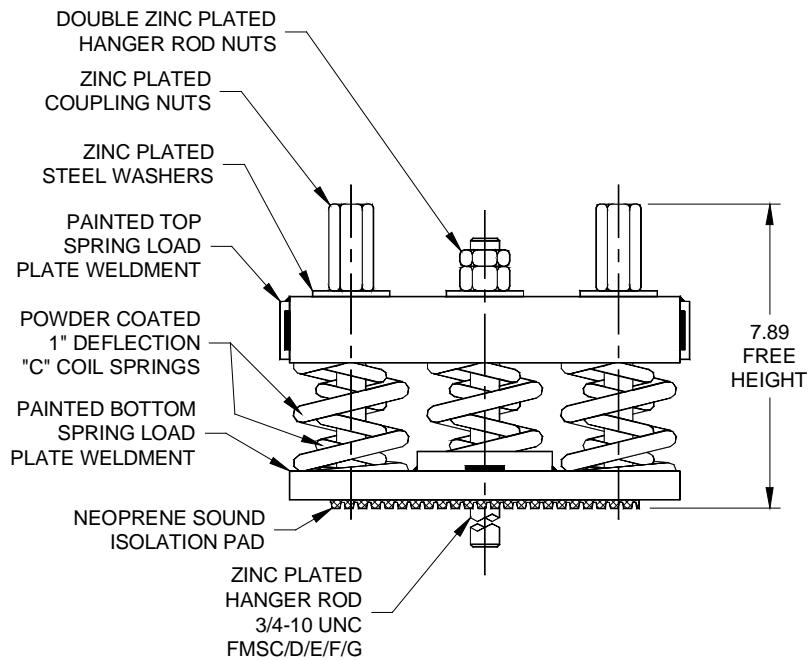

1" DEFLECTION – TRIPLE “C” COIL ISOLATION SUBMITTAL DATA

PAGE 3 OF 4

RELEASE DATE: 5/6/04



DUBLIN, OHIO, USA • MISSISSAUGA, ONTARIO, CANADA

Toll Free (USA only): 800-959-1229
 International: 614-889-0480
 Fax: 614-889-0540
 World Wide Web: www.kineticsnoise.com
 Email: sales@kineticsnoise.com

DOCUMENT:

P2.3.2



1 Deflection – Quad “C” Coil Sets – 9,860 lbs to 14,000 lbs

ISOLATOR MODEL	USED WITH FMS MODELS	RATED LOAD (LBS)	DEFLECTION @ RATED LOAD (IN)	SPRING RATE (LBS/IN)	SPRING COLOR OUTER/INNER	LOAD @ 1 IN. DEFLECTION (LBS)
1-9860	E/F/G	9,860	1.00	9,860.0	Blue/-----	9,860
1-11460	E/F/G	11,460	1.00	11,460.0	Blue/Gray	11,460
1-14000	E/F/G	14,000	1.00	14,000.0	Blue/Brown	14,000

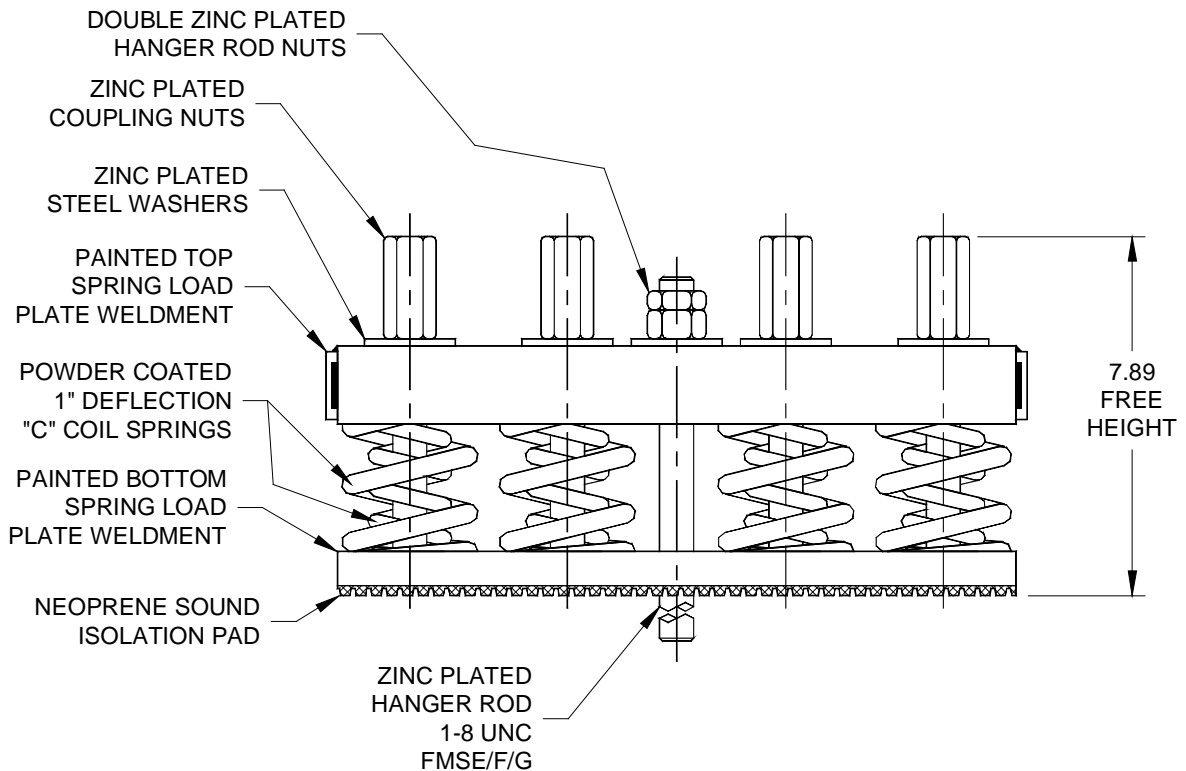

1" DEFLECTION – QUAD “C” COIL ISOLATION SUBMITTAL DATA

PAGE 4 OF 4

RELEASE DATE: 5/6/04



Toll Free (USA only): 800-959-1229
 International: 614-889-0480
 Fax: 614-889-0540
 World Wide Web: www.kineticsnoise.com
 Email: sales@kineticsnoise.com

DOCUMENT:
P2.3.2
 VISCMA
 MEMBER