

Pros and Cons of Struts Versus Cables

Both cables and struts have their place in the restraint of conduit and other electrical distributions systems. In order to minimize costs and speed up installation, the differences between the two should be understood.

In general, distribution systems restrained by struts will require only 1 brace per restraint location while systems restrained with cables requires that 2 cables be fitted forming an "X" or a "V". As a trade-off, the number of restraint points needed on a given run of conduit or distribution ducts will typically be considerably higher for a strut-restrained system than for the cable-restrained system and, generally, strut-restrained systems will be more costly to install.

An added factor to consider when selecting a restraint system is that once a decision is reached on the type to use for a particular run, code requirements state that the same type of system must be used for the entire run (all cable or all strut). Later sections in this chapter will define runs, but for our purposes at present, it can be considered to be a more or less straight section of piping.

The obvious advantage to struts is that, when space is at a premium, cables angling up to the ceiling on each side of a run may take more space than is available. Struts can be fitted to one side only, allowing a more narrow packaging arrangement.

The advantages of cables, where they can be used, are numerous. First, they can usually be spaced less frequently along a distribution run than can struts. Second, they cannot increase the tensile forces in the hanger rod that results from the weight load, so rod and rod anchorage capacities are not impacted. And third, they are easily set to the proper length.

To better explain the differences between the systems, it is necessary to look at how seismic forces are resisted with cables and struts. Shown below are sketches of both a cable-restrained and strut-restrained piece of conduit.

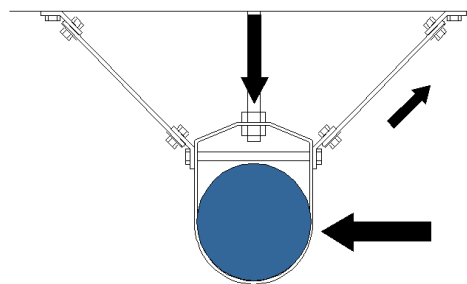

Cable Restrained

PROS AND CONS OF STRUTS VERSUS CABLES

PAGE 1 OF 4

RELEASE DATE: 10/11/04



DUBLIN, OHIO, USA • MISSISSAUGA, ONTARIO, CANADA

Toll Free (USA only): 800-959-1229
International: 614-889-0480
Fax: 614-889-0540
World Wide Web: www.kineticsnoise.com
Email: sales@kineticsnoise.com

DOCUMENT:

D9.3



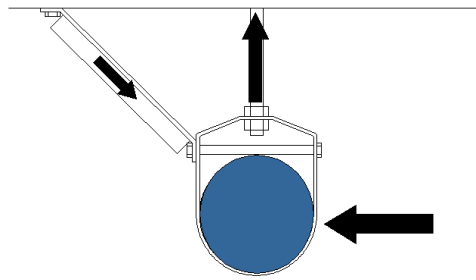

Strut Restrained

The key factor to note is that cables can only be loaded in tension. This means that seismic forces can only generate compressive loads in the hanger rod. Seismic forces can, however, load the strut in compression resulting in a tensile load on the hanger rod.

This tensile load is in addition to any deadweight load that may already be supported by the hanger and is often significantly higher than the original load. This has the potential to rip the hanger rod out of the support structure and must be considered when sizing components.

Because of this added tensile component and the resulting impact on the necessary hanger rod size, most strut manufacturers limit the maximum allowable strut angle (to the horizontal) to 45 degrees. This is lower than typical allowable angles for cables that often reach 60 degrees from the horizontal. Although the tables listed in Chapter D4 of this manual allow the use of higher angles for strut systems, users will find that the penalties in hanger rod size and anchorage will likely make these higher angles unusable in practice. To put this into context, examples will be provided at both 45 degrees and 60 degrees from the vertical to indicate the impact on capacity that results from the angle.

For a 45 degree restraint angle, if we assume a trapeze installation with the weight (W) equally split between 2 supports, the initial tension in each support is $0.5W$. Using a $0.25g$ lateral design force (low seismic area), the total tensile load in a hanger increases to $0.75W$ for bracing on every support and $1.0W$ for bracing on every other support, if a strut is used.

For reference, if struts are used in a 60 degree angle configuration (from the horizontal), the tensile force in the hanger rod for all cases increases by a factor of 1.73 ($\tan 60$) over that listed in the previous paragraph. This means that the tensile force becomes $.94W$ for bracing on every support and $1.36W$ for bracing on every other support.

On the other hand, where $0.25g$ is applicable, buckling concerns in conduit are such that the spacing between lateral restraints can be as high as 40 ft and for axial restraints, 80 ft. If we were to try to use struts placed at a 40 ft spacing in conjunction with supports spaced at 10 ft, the tensile force developed by a seismic event in the rod increases to

PROS AND CONS OF STRUTS VERSUS CABLES



DUBLIN, OHIO, USA • MISSISSAUGA, ONTARIO, CANADA

Toll Free (USA only): 800-959-1229
 International: 614-889-0480
 Fax: 614-889-0540
 World Wide Web: www.kineticsnoise.com
 Email: sales@kineticsnoise.com

DOCUMENT:
D9.3
 VISCMA
 MEMBER

1.5W for 45 degree configurations and to 2.23W for 60 degree configurations.

As mentioned earlier, there is no increase in the rod forces for cable restrained systems.

Using real numbers based on a 40 ft restraint spacing and a 60 degree angle configuration, if the peak tensile load in the hanger rod is 500 lb for a cable restrained system, it becomes 2230 lb for an otherwise identical strut restrained system.

A summary of the above data, based on a 500 lb weight per hanger rod (1000 lb per trapeze bar) and including concrete anchorage sizes and minimum embedment is shown below.

Summary of Hanger Rod Tensile Loads based on 500 lb per Rod Weight				
	Tens Force (lb)	Min Rod (in)	Min Anc (in)	Embed (in)
Every Hanger Braced (10')				
Cable Angle = 45	500	0.38	0.38	3.00
Strut Angle = 45	750	0.38	0.38	3.00
Cable Angle = 60	500	0.38	0.38	3.00
Strut Angle = 60	933	0.50	0.50	4.00
Every other Hanger Braced (20')				
Cable Angle = 45	500	0.38	0.38	3.00
Strut Angle = 45	1000	0.50	0.50	4.00
Cable Angle = 60	500	0.38	0.38	3.00
Strut Angle = 60	1365	0.50	0.63	5.00
Every fourth Hanger Braced (40')				
Cable Angle = 45	500	0.38	0.38	3.00
Strut Angle = 45	1500	0.63	0.63	5.00
Cable Angle = 60	500	0.38	0.38	3.00
Strut Angle = 60	2230	0.63	0.75	6.00
Max Spacing between Braces (80')				
Cable Angle = 45	500	0.38	0.38	3.00
Strut Angle = 45	2500	0.75	0.75	6.00
Cable Angle = 60	500	0.38	0.38	3.00
Strut Angle = 60	3960	0.88	1.00	8.00

Note: The above anchorage rating is based on ICBO allowables only. Often the underside of a concrete floor slab is in tension and if this is the case, the anchorage capacity may need to be further de-rated (forcing the need for an even larger hanger rod than is indicated here).

The net result is that the ability to use struts is highly dependent on the hanger rods that are in place. If these were sized simply on deadweight, the added seismic load, even in relatively low seismic areas, can quickly overload them. The only recourse is to either replace the hanger rods with larger ones or decrease the restraint spacing to the point at

PROS AND CONS OF STRUTS VERSUS CABLES



Toll Free (USA only): 800-959-1229
 International: 614-889-0480
 Fax: 614-889-0540
 World Wide Web: www.kineticsnoise.com
 Email: sales@kineticsnoise.com



which virtually every support rod is braced.

It should also be noted that the hanger rods in tension become seismic elements. This occurs with struts, but does not with cables. As a result, the system must comply with all of the anchor requirements specified by ICBO. This includes the use of wedge-type anchors and embedment depths that are a minimum of 8 anchor diameters. With larger anchor sizes, floor slab thickness may cause this to become a significant problem.

With both cables and struts, the hanger rods can be loaded in compression. As the seismic force increases, it eventually overcomes the force of gravity and produces a buckling load in the hanger rod. It is mandatory in all cases that the rod be able to resist this force.

There is a wide range of variables involved in determining the need for rod stiffeners to resist this buckling load. Factors that impact this need are 1) the magnitude of the compressive force, 2) the weight load carried by the hanger rod, 3) the length of the hanger rod, 4) the diameter of the hanger rod, and 5) the angle between the restraint strut or cable and the horizontal axis.

Tables are included in Chapter D4 of this manual that allow the user to determine if there is a need for a stiffener and to allow the proper selection if required.

In rare instances, electrical distribution systems are isolated. In these cases and because uplift occurs, some attention must be given to the isolator itself. First, when using isolators, the location of the isolation element needs to be at the top end of the hanger rod (close to, but not tight against the ceiling). If placed at the middle of the hanger rod, the rod/isolator combination will have virtually no resistance to bending and will quickly buckle under an uplift load.

Second, a limit stop must be fit to the hanger rod, just beneath the hanger such that when the rod is pushed upward a rigid connection is made between the hanger housing and the hanger rod that prevents upward motion. This is accomplished by adding a washer and nut to the hanger rod just below the isolator (see the sketch below).

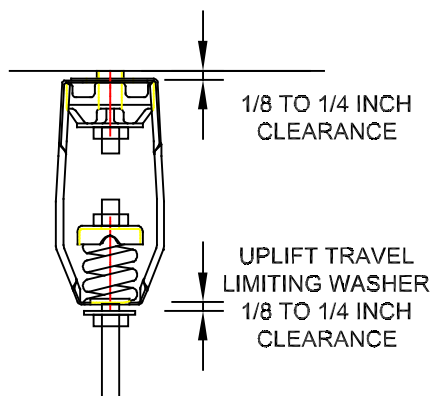

PROS AND CONS OF STRUTS VERSUS CABLES

KINETICS
Noise Control

DUBLIN, OHIO, USA • MISSISSAUGA, ONTARIO, CANADA

Toll Free (USA only): 800-959-1229
 International: 614-889-0480
 Fax: 614-889-0540
 World Wide Web: www.kineticsnoise.com
 Email: sales@kineticsnoise.com

DOCUMENT:
D9.3

VISCMA
MEMBER