

KINETICS®

Vibration Isolators

Model KPM



Description and Application

Kinetics Model KPM Vibration Isolation Mounts consist of a molded elastomeric isolator.

Each isolator is of a molded elastomeric material which has been specially designed to safely support the imposed load under vibrating conditions. The proprietary elastomeric design provides a low vertical and horizontal spring rate without settling, age-stiffening, or an increase in hardness that can occur with conventional rubber isolators.

The rated natural frequencies of 4.0 Hz in the vertical direction and 2.0 Hz in the horizontal direction yield outstanding vibration isolation capabilities against most typical structure-borne sources.

The vertical rated load capacity of the Model KPM-2500 vibration isolation mount is 2500 pounds, with a rated vertical deflection of 0.80 inches. Higher or lower capacities are available upon request.

Application

Kinetics Model KPM vibration isolation mounts are used to isolate structure-borne noise and severe vibration generated by machinery on grade or at higher elevations. KPM isolators are also used to support sensitive equipment away from structure-borne vibration which might otherwise disturb the operation of the equipment.

Typical applications for the Model KPM vibration isolation mount are for the isolation of mechanical equipment such as pumps, chillers, electrical generators and related equipment. Rotating or reciprocating industrial machinery can also be isolated with the Model KPM mount.

Sensitive precision electronic equipment such as computers, lasers, and measuring machines can be protected against floor-borne vibrations with KPM mounts.

Model KPM mounts can be used to directly support isolated equipment, or they can be used beneath steel or concrete bases. The low natural frequency of KPM isolators compares favorably with conventional steel or air spring isolators. KPM isolation mounts are completely passive and require no maintenance after installation.

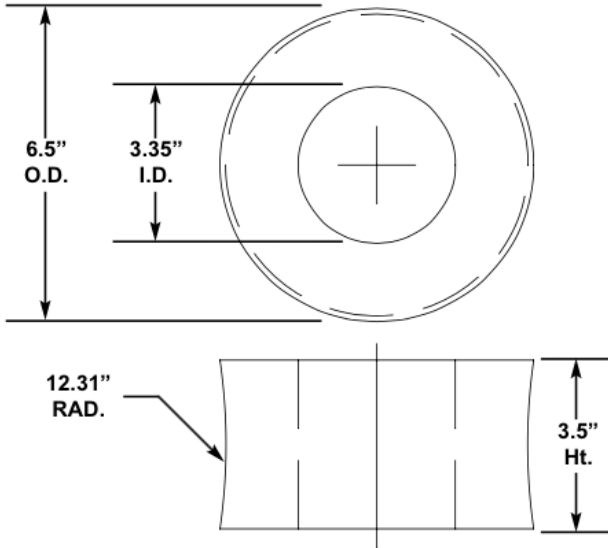

Specifications

Vibration isolators shall consist of a one-piece molded elastomeric isolator. The elastomeric isolation element shall not age stiffen, settle, or increase in hardness during the life of the isolator.

The vertical natural frequency of the isolator shall be 4.0 Hz at rated load and the vertical deflection shall not exceed 0.80 inches at a vertical load of 2500 lbs. The horizontal natural frequency shall not exceed 2.5 Hz at the same vertical load. The vibration isolators shall be maintenance-free and not require internal air pressure for isolator support.

Vibration isolator shall be Model KPM as manufactured by Kinetics Noise Control, Dublin, Ohio.

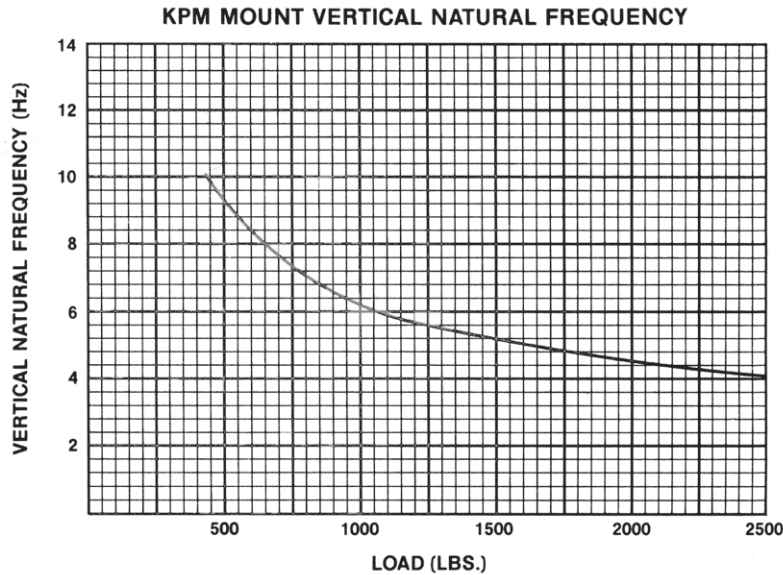

kineticsnoise.com
sales@kineticsnoise.com
1-800-959-1229