

A B

C

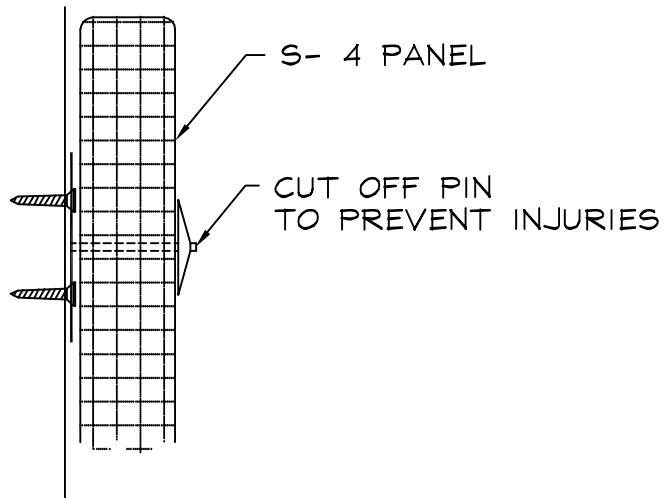

1. DETERMINE EXACT PANEL LOCATIONS
2. FASTEN IMPALING PINS TO WALL WITH SCREWS OR CONSTRUCTION ADHESIVE
3. IMPALE PANEL ONTO PINS
4. CUT OFF EXCESS PIN LENGTH

PANEL LENGTH	# OF CLIPS
UP TO 24"	4
24" TO 48"	4
48" TO 72"	4 - 6
72" TO 96"	6 - 8

NOTE: CONSTRUCTION ADHESIVE MAY BE USED IN ADDITION IF DESIRED