

# KINETICS™

## Seismic Engineering Capabilities

- Computer-generated static analysis for all US and Canadian codes for isolated or rigid-mounted equipment
- Bomb blast and custom seismic requirements
- Custom dynamic analysis for specialty applications
- Piping and duct work analysis for location and selection of seismic restraints
- Specification development and assistance
- Field analysis and installation supervision

INPUT DATA	KNC PO: KNC01 <b>KINETICS SEISMIC CERTIFICATION</b> TYP PUMP (A)																							
PROJECT DATA	<b>Input Data</b> Project: <b>Sample Project</b> Representative: <b>KNC Representative</b> P.O. Number: <b>12345</b> Date: <b>02-11-2004</b> Code Used: <b>2000IBC</b> Min Horiz G: <b>.00</b> Equip Type: <b>SAMPLE PUMP</b> Tag: <b>TYP PUMP</b> Min Vert G: <b>.00</b> Installation Type: <b>Base Mounted, Common Support/Restraint Loc</b> Code G (ASD): <b>.47/.06 (H/V)</b> Soil Type: <b>Sd (1.4)</b> Fault Type: <b>n/a</b> Fault Proximity: <b>n/a</b> Conc Ancs(ASD): <b>.61/.06 (H/V)</b>																							
INSTALLATION SCHEMATICS			Data used is derived from Customer input, others are responsible for the accuracy of this data. Wgt(lb): <b>2500</b> Elev-Roof/Equip: <b>30/15 ft</b> Geometry (in): Ap: <b>2.50</b> Ss: <b>.44</b> l: <b>1.00</b> Rp s/c: <b>2.50/2.50</b> A: <b>84.00</b> B: <b>44.00</b> ex: <b>8.00</b> ey: <b>1.50</b> Hgt (CG to Restraint): <b>6.25</b>																					
OUTPUT DATA	<b>Output Data</b> Certification Loads (Seismic) (lb) Static Load <b>-471</b> <b>-540</b> <b>-693</b> <b>-795</b> Max Uplift Load at Loc: <b>121</b> <b>121</b> <b>121</b> <b>121</b> Max Horiz Load at Loc: <b>222</b> <b>254</b> <b>326</b> <b>373</b> Effective Corner Wt <b>-472</b> <b>-541</b> <b>-694</b> <b>-795</b>		<b>Restraint Data</b> Total # of Restraints: <b>4</b> Restraints/Side on Lg Axis: <b>2</b> Restraints/Side on Sht Axis: <b>2</b> Restraint Type: <b>FHS(Isolated) &gt; 8 Dias.</b> Loc 1: <b>1-250/2200</b> Loc 2: <b>1-250/2200</b> Loc 3: <b>1-250/2200</b> Loc 4: <b>1-250/2200</b>																					
SEISMIC FORCE																								
SAFETY FACTORS	Calculated Restraint Safety Factors (Must be greater than or equal to 1) <table style="width: 100%; border-collapse: collapse;"> <thead> <tr> <th></th> <th style="text-align: center;">Loc 1</th> <th style="text-align: center;">Loc 2</th> <th style="text-align: center;">Loc 3</th> <th style="text-align: center;">Loc 4</th> </tr> </thead> <tbody> <tr> <td>Restraint SF if Welded to Steel</td> <td style="text-align: center;"><b>14.16</b></td> <td style="text-align: center;"><b>12.69</b></td> <td style="text-align: center;"><b>10.20</b></td> <td style="text-align: center;"><b>9.00</b></td> </tr> <tr> <td>Restraint SF if Bolted to Steel</td> <td style="text-align: center;"><b>14.16</b></td> <td style="text-align: center;"><b>12.69</b></td> <td style="text-align: center;"><b>10.20</b></td> <td style="text-align: center;"><b>9.00</b></td> </tr> <tr> <td>Restraint SF if Anchored to Concrete</td> <td style="text-align: center;"><b>8.78</b></td> <td style="text-align: center;"><b>7.65</b></td> <td style="text-align: center;"><b>5.74</b></td> <td style="text-align: center;"><b>4.84</b></td> </tr> </tbody> </table>					Loc 1	Loc 2	Loc 3	Loc 4	Restraint SF if Welded to Steel	<b>14.16</b>	<b>12.69</b>	<b>10.20</b>	<b>9.00</b>	Restraint SF if Bolted to Steel	<b>14.16</b>	<b>12.69</b>	<b>10.20</b>	<b>9.00</b>	Restraint SF if Anchored to Concrete	<b>8.78</b>	<b>7.65</b>	<b>5.74</b>	<b>4.84</b>
	Loc 1	Loc 2	Loc 3	Loc 4																				
Restraint SF if Welded to Steel	<b>14.16</b>	<b>12.69</b>	<b>10.20</b>	<b>9.00</b>																				
Restraint SF if Bolted to Steel	<b>14.16</b>	<b>12.69</b>	<b>10.20</b>	<b>9.00</b>																				
Restraint SF if Anchored to Concrete	<b>8.78</b>	<b>7.65</b>	<b>5.74</b>	<b>4.84</b>																				
ANCHOR ATTACHMENT	<table style="width: 100%; border-collapse: collapse;"> <thead> <tr> <th></th> <th style="text-align: center;">0.75 / 2</th> <th style="text-align: center;">0.75 / 2</th> <th style="text-align: center;">0.75 / 2</th> <th style="text-align: center;">0.75 / 2</th> </tr> </thead> <tbody> <tr> <td>Anchor/Attachment Bolt Size/Qty</td> <td></td> <td></td> <td></td> <td></td> </tr> <tr> <td>Min Anchor Embedment Req'd</td> <td style="text-align: center;"><b>5"</b></td> <td style="text-align: center;"><b>5"</b></td> <td style="text-align: center;"><b>5"</b></td> <td style="text-align: center;"><b>5"</b></td> </tr> </tbody> </table>					0.75 / 2	0.75 / 2	0.75 / 2	0.75 / 2	Anchor/Attachment Bolt Size/Qty					Min Anchor Embedment Req'd	<b>5"</b>	<b>5"</b>	<b>5"</b>	<b>5"</b>					
	0.75 / 2	0.75 / 2	0.75 / 2	0.75 / 2																				
Anchor/Attachment Bolt Size/Qty																								
Min Anchor Embedment Req'd	<b>5"</b>	<b>5"</b>	<b>5"</b>	<b>5"</b>																				
WELD ATTACHMENT	If welded, each bracket corner requires 4.50 linear inches of .25 weld.																							
GENERAL NOTES	Note: Bolt Safety Factors based on the capacity of Type A-307 hardware to handle uplift after all horizontal loads are accounted for. Min Edge Distance - See Anchor Data Sheet Safety Factors listed as 100 indicate 100 or greater For a detailed summary of how these loadings were derived, contact KINETICS NOISE CONTROL, Inc. KNC certifies that the seismic/wind isolation and or restraint system described on this sheet is adequate to resist the certification loads specified herein. The use of hardware other than that provided by KNC voids this certification. <small>This certification addresses the load path from the equipment point connection to the connection point of the structure. Others must verify the ability of the equipment or structure to resist these loads. See also the included disclaimer, Certification void if disclaimer and Certification Cover Sheet not included. In connection with this certification and the application of the certification design loads to the project, KINETICS NOISE CONTROL, Inc guarantees that we will use that degree of care and skill ordinarily exercised under similar conditions by reputable members of our profession to determine restraint loadings and Safety Factors based on customer supplied input data. No other warranty, expressed or implied, is made or intended. 02/04/2004</small>																							

# KINETICS™

## Seismic Restraint for Isolated and Suspended Mechanical Equipment

for -

- Piping
- Fans
- VAV & Fan Terminal Boxes
- Silencers & Mufflers
- Ductwork
- Air Handlers

### Kinetics KSCA Cable Attachment Bracket

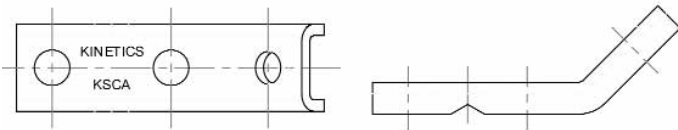

### Kinetics KSUA Cable Attachment Bracket

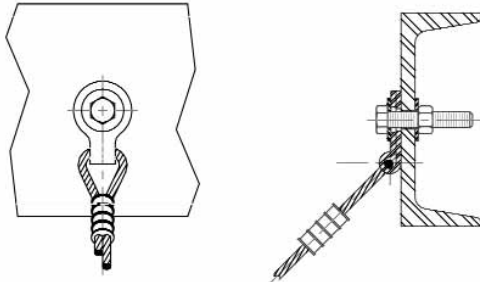

### Kinetics Seismic Cable Restraint Kit

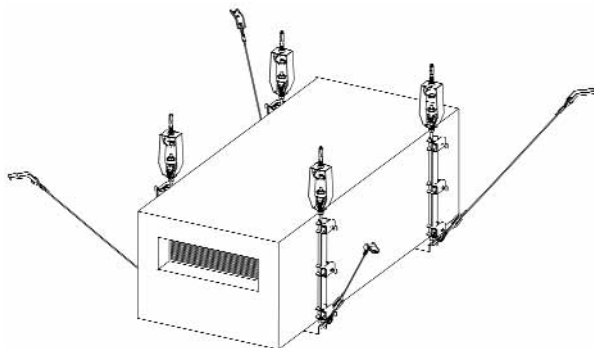
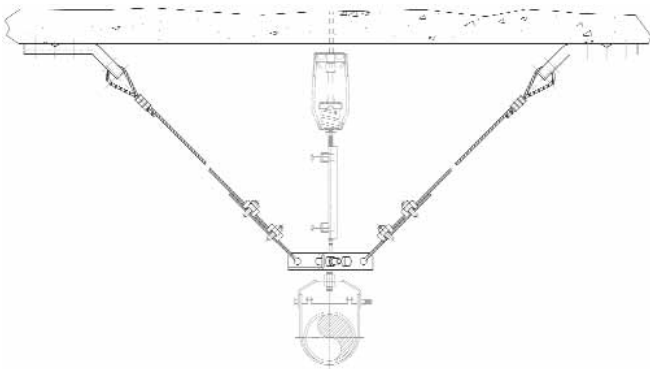

# KINETICS™

## Floor-Mounted Seismic Restraints

### Seismic Control Spring Isolators

#### Model FHS

- Combination spring isolator & seismic restraint
- All-directional restraint with vertical limit stops

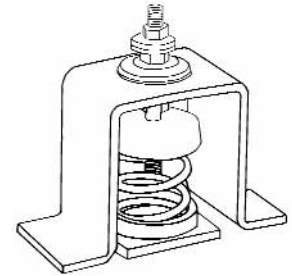

### Seismic Snubber

#### Model HS-5

- Double axis horizontal and vertical seismic restraint
- Standard capacities to 3,275 lbs.
- Can be bolted or welded in place

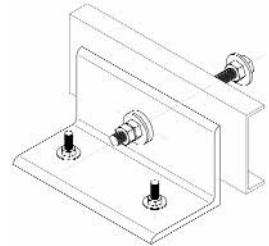

### Modular Restraint/Isolator

#### Model FMS

- Can be used as a restraint device or as a seismically rated vibration isolator assembly
- Restraint components are available in 8 sizes with horizontal force ratings to 70,000 lbs.
- Standard isolation elements are available to 4" deflection with support capacities to 23,000 lbs.
- Ideal for equipment mounted on structural frame or concrete inertia bases

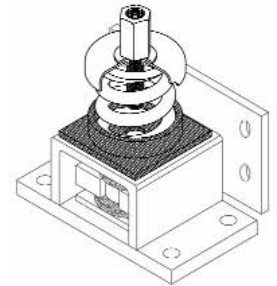

Kinetics FMS with isolator

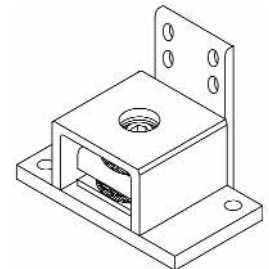

Kinetics FMS without isolator



United States 6300 Ireland Place P.O. Box 655 Dublin, Ohio 43017 Phone: 614-889-0480 Fax: 614-889-0540	Canada 1720 Meyerside Drive Mississauga, Ontario L5T 1A3 Phone: 905-670-4922 Fax: 905-670-1698
---	---

[www.kineticsnoise.com](http://www.kineticsnoise.com)  
[sales@kineticsnoise.com](mailto:sales@kineticsnoise.com)

Kinetics Noise Control, Inc. is continually upgrading the quality of our products. We reserve the right to make changes to this and all products without notice.