



*Assembled curb with EPDM weatherseal attached*

### Standard Features

- Internal seismic and wind restraint
- 1-, 2-, and 3-inch a deflection springs\*
- Supply and return flexible connector support hardware (flex connectors by others)
- EPDM air and weather-tight seal for non-ducted applications
- Standard curb height of 24.75"
- Adjustable and interchangeable springs

*\*Per the design work the options for deflection are 1-, 2-, 3-, and 4-inch. The curb heights are 24.75-, 24.75-, 27- and 28.88-inches, respectively.*

### Options

- Multiple roof pitch interface
- Additional height
- Exterior thermal insulation
- Acoustical treatments available:
  - 1" fiber glass absorber along inside perimeter of curb
  - 2" fiber glass absorber in bottom of curb
  - High-mass composite floating floor in bottom of curb
- Certification of seismic and wind load Engineering
- Silencers/Acoustical plenums for supply and return sound control

### Specifications

All rooftop air-handling units shall be supported by vibration isolation curbs as manufactured by Kinetics Noise Control. The vibration isolation curbs shall be complete assemblies designed to resiliently support the equipment at the specified elevation and shall constitute a fully enclosed air- and weather-tight system.

The isolation curb shall consist of an upper structural steel support rail with supply and return flexible connector supports on which the equipment and duct openings rest and a lower support curb which is attached to the roof structure,

# KINETICS™

## Roof Curb and Isolation System

### KineticsCurb



*Adjustable and Interchangeable Spring Coils*



*Vertical and Horizontal Seismic/Wind Restraints. Meets the current IBC Building Codes*

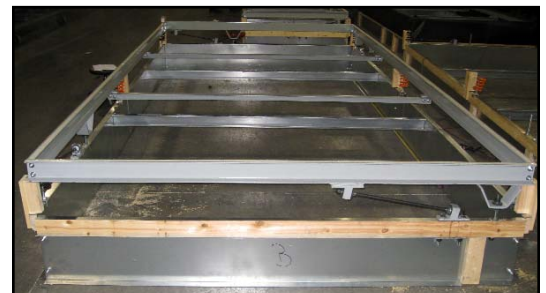

*Flexible Supply and Return Duct Support Hardware Installed*

separated by freestanding, unhoused, laterally stable steel springs and lateral seismic and/or wind load restraints.

The upper support rail shall provide continuous structural steel support for the rooftop equipment and shall be designed to provide isolation against casing-radiated vibration in the rooftop equipment housing and structure borne vibration from rotating and mechanical equipment in the rooftop package.

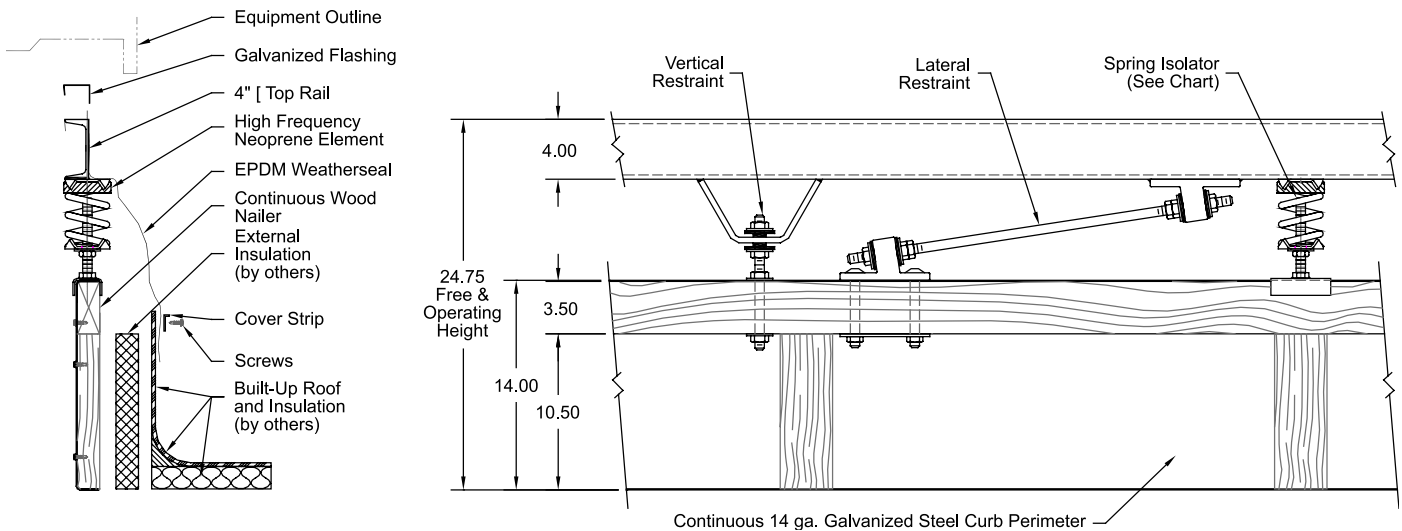

The upper support rail shall consist of structural steel channel with a minimum height of 4" (121 mm) above the spring to preclude interference with the rooftop equipment and permit access to inspect, level, or change the springs after placement of the rooftop equipment.

The lower support curb shall be a formed channel fabricated of heavy gauge galvanized steel with a continuous 3-1/2" x 1-1/2" (89 mm x 38 mm) nominal wood nailer. The base plate of the curb shall be 1-1/2" (38 mm) wide and shall be welded, bolted or screwed to the building support steel. The lower support curb shall have a minimum elevation of 14" (356 mm). Spring components shall be (1"/25 mm) (2"/51 mm) deflection, free-standing, unhoused, laterally stable steel springs. Springs shall have a lateral stiffness greater than 1.0 times the rated vertical stiffness and shall be designed for a typical 50% overload to solid. All springs shall have an epoxy-based, powder-coated finish and be color coded to indicate load capacity.

The vibration isolation curb shall be air and weather tight using an elastomeric seal, which is attached to the upper support frame with a galvanized steel clip. The seal shall extend down past the wood nailer of the lower support assembly and flash over the roof material at the wood nailer on the lower support curb. The seal shall be Class A, as tested in accordance with approved Underwriter's Laboratories, Inc., provisions. Metal or combination metal and elastomer seals are not permitted. Spring must be accessible without the need to penetrate or damage installed roof membrane or flashing.

Supply and return flexible connector support hardware shall be supplied for installation by the contractor in the field. The supports will be clearly marked and dimensioned on the submittal and installation drawings. The support hardware shall be cut-to-length, galvanized steel channels supported and connected with stamped and punched galvanized steel duct support hangers. The support hangers shall allow the duct support elevation to be equal to or lower than the equipment rail elevation. Supply and return air duct shall be flexibly attached by the contractor to prevent transmission of vibration to the building structure. The flex connectors shall be furnished by others.

The isolation curb assemblies shall be shipped to the job site fully assembled with the upper support rail, lower support curb, springs, stabilizers

and duct supports completely assembled. Units exceeding freight limitations will be split and assembled in the field by others.

Vibration isolators shall be selected by the manufacturer for each specific application to comply with deflection requirements as shown on the Vibration Isolation Schedule or as indicated on the project documents.

### Optional Certification

The manufacturer shall submit certified engineering drawings and calculations stamped by a licensed Professional Engineer demonstrating the isolation curb system has been designed (for a \_\_\_mph/\_\_\_km/h wind load), (for seismic Zone \_\_\_per code), (to withstand \_\_\_g horizontal force and \_\_\_g vertical force).

Roof curb shall be Model KineticsCurb as manufactured by Kinetics Noise Control Inc.



<b>United States</b> 6300 Irelean Place P.O. Box 655 Dublin, Ohio 43017 Phone: 614-889-0480 Fax: 614-889-0540	<b>Canada</b> 3570 Nashua Drive Mississauga, Ontario L4V 1L2 Phone: 905-670-4922 Fax: 905-670-1698
--	---

[www.kineticsnoise.com](http://www.kineticsnoise.com)  
[sales@kineticsnoise.com](mailto:sales@kineticsnoise.com)

Kinetics Noise Control, Inc. is continually upgrading the quality of our products. We reserve the right to make changes to this and all products without notice.