

Description

Kinetics HSR Thrust Restraints are used to counteract the discharge force created by fans during operation. HSR Thrust Restraints are used in pairs and best utilized when located on the centerline of the discharge outlet of the fan, bridging the flexible duct connector.

HSR Thrust Restraints consist of high deflection, large diameter, laterally stable steel coil springs assembled into a threaded rod and bracket assembly. The coil springs have a lateral spring stiffness greater than 1.0 times the rated vertical stiffness to assure coil stability. The coil springs are designed to provide a minimum of 50% overload deflection capability to solid. The coil springs are polyester powder coated for corrosion protection, having passed a 1,000 hour salt spray test per ASTM Standard B-117. HSR thrust restraints feature molded neoprene end load plate assemblies for light capacities. For heavier capacities, Model HSR utilizes stamped steel end cups. HSR Thrust Restraints include threaded adjustment rod with hardware, fan and ductwork mounting bracket angles, bracket back-up plates, and all attachment hardware.

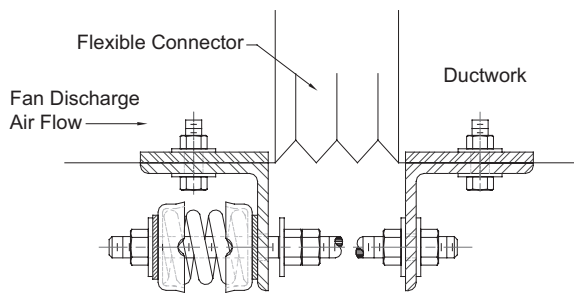

Specifications

Thrust Restraints shall consist of high deflection, large diameter, laterally stable steel coil springs assembled into a threaded rod and angle bracket assembly. Coil springs shall have a lateral spring stiffness greater than 1.0 times the rated vertical stiffness to assure coil stability. Coil springs shall provide a minimum of 50% overload deflection capability to solid and shall be safe when temporarily loaded to solid capacity. Coil springs shall be polyester powder coated for corrosion protection and shall demonstrate successful completion of a 1000 hour salt spray test per ASTM Standard B-117. Thrust Restraints shall feature molded neoprene end load plate assemblies for light capacities or stamped steel end cups for heavier capacities. Thrust Restraints shall include threaded adjustment rod with zinc-plated hardware, and shall include primer painted fan and ductwork mounting bracket angles, bracket back-up plates, and complete fan / ductwork attachment hardware.

Thrust Restraints shall be Model HSR as manufactured by Kinetics Noise Control, Inc.

KINETICS®

Thrust Restraint Model HSR



Application

ASHRAE recommends that thrust restraints such as Kinetics HSR incorporate the same coil spring deflection as the support isolators. HSR Thrust Restraints are to be used for all fan heads, suspended fans, and all base-mounted and suspended air-handling equipment operating at 2 inches or greater total static pressure (TSP). HSR Thrust Restraints are always installed in pairs and often work in conjunction with inertia bases for floor-mounted fans to counteract fan thrust.

Total fan thrust can be calculated using the following formula:

$$\text{Thrust (lbs.)} = \frac{0.036 \times \{TSP \text{ (in.)}\} \times \{Fan \text{ Discharge Outlet Area (sq. in.)}\}}{2}$$

To select the correct HSR Thrust Restraint to be used, this total calculated thrust is to be divided by two (2) and then rounded up to the next highest standard coil spring capacity.

Kinetics HSR Thrust Restraints are best utilized when located on the centerline of the discharge outlet of the fan. Fan instability can occur when attempts are made to control fan thrust only at the (floor-mounted) isolator locations. The attachment of the HSR brackets must be made at structurally sound locations and cannot be attached to bare unreinforced sheet metal ductwork.

The HSR coil spring is to be preloaded to allow for approximately 0.25" (6 mm) of additional deflection due to fan motion upon start-up. HSR Thrust Restraint movement adjustment must be made under normal fan operational static pressures.

Isolator Type	Spring Coil				Rated				Dimensions								
	Color	Free HT		O.D.		Load		Deflection		A		C		E		H	
		in	mm	in	mm	lbs	kg	in	mm	in	mm	in	mm	in	mm	in	mm
HSR-1-35	Blue	3.19	81	1.75	44	35	16	1.52	39	3.50	89	1.25	32	1.75	44	3.00	76
HSR-1-70	Green	3.19	81	1.75	44	70	32	1.36	35	3.50	89	1.25	32	1.75	44	3.00	76
HSR-1-120	Gray	3.19	81	1.75	44	120	54	1.18	30	3.50	89	1.25	32	1.75	44	3.00	76
HSR-1-220	Brown	3.19	81	1.75	44	220	100	1.07	27	3.50	89	1.25	32	1.75	44	3.00	76
HSR-1-370	Orange	3.19	81	1.75	44	370	168	0.96	24	3.50	89	1.25	32	1.75	44	3.00	76
HSR-1-500	Beige	3.19	81	1.75	44	500	227	1.00	25	3.50	89	1.25	32	1.75	44	3.00	76
HSR-1-600	Chrome	3.19	81	1.75	44	600	272	1.00	25	3.50	89	1.25	32	1.75	44	3.00	76
HSR-1-50	Beige	4.20	107	3.00	76	50	23	1.00	25	5.00	127	1.00	25	2.50	64	4.00	102
HSR-1-100	Chrome	4.20	107	3.00	76	100	45	1.00	25	5.00	127	1.00	25	2.50	64	4.00	102
HSR-1-250	Blue	4.20	107	3.00	76	250	113	1.79	45	5.00	127	1.00	25	2.50	64	4.00	102
HSR-1-450	Green	4.20	107	3.00	76	450	204	1.54	39	5.00	127	1.00	25	2.50	64	4.00	102
HSR-1-625	Black	4.20	107	3.00	76	625	284	1.44	37	5.00	127	1.00	25	2.50	64	4.00	102
HSR-1-800	Gray	4.20	107	3.00	76	800	363	1.31	33	5.00	127	1.00	25	2.50	64	4.00	102
HSR-1-1000	Red	4.20	107	3.00	76	1000	454	1.15	29	5.00	127	1.00	25	2.50	64	4.00	102
HSR-1-1250	Brown	4.20	107	3.00	76	1250	568	1.09	28	5.00	127	1.00	25	2.50	64	4.00	102
HSR-1-1700	Orange	4.20	107	3.00	76	1700	772	0.95	24	5.00	127	1.00	25	2.50	64	4.00	102
HSR-1-2200	Org/Gry	4.20	107	3.00	76	2200	999	1.00	26	5.00	127	1.00	25	2.50	64	4.00	102
HSR-1-2465	Blue	4.20	107	3.00	76	2465	1119	1.00	25	5.00	127	1.00	25	2.50	64	4.00	102
HSR-1-2865	Blu/Gry	4.20	107	3.00	76	2865	1301	1.00	25	5.00	127	1.00	25	2.50	64	4.00	102
HSR-1-3500	Blu/Brn	4.20	107	3.00	76	3500	1589	1.00	25	5.00	127	1.00	25	2.50	64	4.00	102
HSR-2-35	Blue	4.13	105	1.75	44	35	16	2.00	51	3.50	89	1.25	32	1.75	44	3.25	83
HSR-2-70	Green	4.13	105	1.75	44	70	32	2.00	51	3.50	89	1.25	32	1.75	44	3.25	83
HSR-2-120	Gray	4.13	105	1.75	44	120	54	2.00	51	3.50	89	1.25	32	1.75	44	3.25	83
HSR-2-220	Brown	4.13	105	1.75	44	220	100	2.00	51	3.50	89	1.25	32	1.75	44	3.25	83
HSR-2-100	Gray	6.09	155	3.50	89	100	45	2.00	51	5.00	127	1.00	25	2.50	64	5.25	133
HSR-2-135	Beige	6.09	155	3.50	89	135	61	2.00	51	5.00	127	1.00	25	2.50	64	5.25	133
HSR-2-185	Brown	6.09	155	3.50	89	185	84	2.00	51	5.00	127	1.00	25	2.50	64	5.25	133
HSR-2-225	Gry/Brn	6.09	155	3.50	89	225	102	2.00	51	5.00	127	1.00	25	2.50	64	5.25	133
HSR-2-250	Blue	6.09	155	3.50	89	250	113	2.00	51	5.00	127	1.00	25	2.50	64	5.25	133
HSR-2-375	Blu/Brn	6.09	155	3.50	89	375	180	2.00	51	5.00	127	1.00	25	2.50	64	5.25	133
HSR-2-500	Green	6.09	155	3.50	89	500	227	2.00	51	5.00	127	1.00	25	2.50	64	5.25	133
HSR-2-625	Grn/Brn	6.09	155	3.50	89	625	283	2.00	51	5.00	127	1.00	25	2.50	64	5.25	133
HSR-2-750	Black	6.09	155	3.50	89	750	340	2.00	51	5.00	127	1.00	25	2.50	64	5.25	133
HSR-2-875	Blk/Brn	6.09	155	3.50	89	875	397	2.00	51	5.00	127	1.00	25	2.50	64	5.25	133
HSR-2-995	Orange	6.09	155	3.50	89	995	451	2.00	51	5.00	127	1.00	25	2.50	64	5.25	133
HSR-2-1120	Org/Brn	6.09	155	3.50	89	1120	508	2.00	51	5.00	127	1.00	25	2.50	64	5.25	133
HSR-2-1400	Org/Grn	6.09	155	3.50	89	1400	635	2.01	51	5.00	127	1.00	25	2.50	64	5.25	133
HSR-2-1600	Red	6.09	155	3.50	89	1600	726	2.00	51	5.00	127	1.00	25	2.50	64	5.25	133
HSR-2-1975	Red/Grn	6.09	155	3.50	89	1975	896	1.98	50	5.00	127	1.00	25	2.50	64	5.25	133

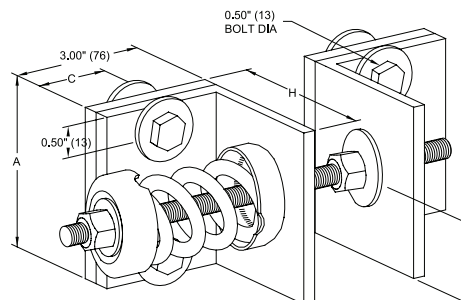

kineticsnoise.com
sales@kineticsnoise.com
1-800-959-1229