

KINETICS™

Seismic Snubber Model HS-5

Description

Kinetics Model HS-5 Seismic Snubbers are designed for use in locations subject to earthquakes, high winds, or other external forces which could displace resiliently supported equipment.

Model HS-5 Seismic Snubbers are intended to limit lateral and vertical equipment motion when placed at the base of vibration-isolated equipment and when securely anchored to the building structure.

Model HS-5 Seismic Snubbers are designed to be used in pairs and will keep supported equipment contained when this equipment is subjected to lateral or vertical forces within the product's design capabilities along any axis. HS-5 Seismic Snubbers can potentially be used with high center-of-gravity isolated equipment once required restraint forces have been calculated and compared to the snubber strength capabilities.

Model HS-5 Seismic Snubbers are heavy structural steel assemblies designed to minimize equipment motion within the product's design capabilities without failing. Resilient neoprene pads at all contact surfaces reduce shock loads by cushioning any potential impacts. Large diameter foundation anchor boltholes allow loads to be safely transferred to the building structure.

Specification

(Equipment) (Equipment Bases) (Concrete inertia bases) (Structural lateral supports) shall be restrained against excessive motion during a seismic event by the use of resilient snubbers designed to meet (0.10) (0.20) (0.25) (0.50) (0.75) (1.00) (1.50) (2.00) "G" loading or to meet current building codes. A registered professional engineer shall design the snubber steel members, or certified test reports shall be submitted which verify the capacity of each snubber.

Snubbers shall be fabricated from structural steel and shall be attached to the building structure in a manner consistent with anticipated loads. Snubbers shall meet all current seismic building codes.

Snubbers shall be placed around equipment as shown on drawings so to limit lateral or vertical motion at each snubber location to 1/8" (3 mm). A minimum of two (2) snubbers shall be installed around each resiliently supported piece of equipment.

Snubbers shall include resilient neoprene pads with bronze backing to cushion any impact and shall be installed and inspected so as to be free of contact during normal non-seismic equipment operation.

Seismic Snubbers shall be model HS-5 as manufactured by Kinetics Noise Control Inc., Dublin, Ohio USA

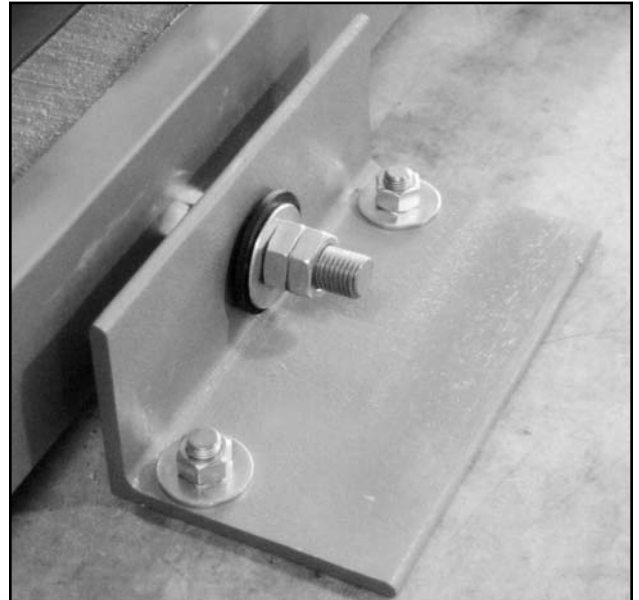

Application

Building codes in many geographic areas require building components to be capable of resisting forces encountered during a seismic event.

Equipment mounted on resilient supports, such as coil spring, neoprene, or fiberglass vibration isolators, can undergo large motions relative to the building during a seismic event. By using properly spaced and designed resilient snubbers around the base of the equipment, this motion can be limited and the equipment can remain in place both during and after the event.

Kinetics Model HS-5 Seismic Snubbers are rugged, heavy-duty products which have been designed to resist imposed forces from external forces. The snubbers remain out of contact during normal equipment / building operation in order that equipment vibration will not be transmitted into the building.

Many applications may require only two (2) HS-5 snubbers since these restraints are capable of withstanding forces in any direction. Note that variations in the equipment center-of-gravity and the specific configuration of the isolated equipment might require the use of additional snubbers.

Kinetics model HS-5 Seismic Snubbers are to be installed such that the neoprene bushing attached to the base anchor will come into contact with the interior surface of the floor mounted angle restraint bracket once the equipment has been displaced approximately 1/8" (3 mm) in any direction.

Installation Instructions

Check the manufacturer's equipment-specific submittal drawings for the precise location of each HS-5 snubber. In lieu of these drawings, HS-5 snubbers should be located at the midpoint of the long axis of the equipment when a pair of snubbers is used. When four (4) HS-5 snubbers are specified, locate these as close to the four (4) equipment corners as possible.

The base anchor rod should be fitted prior to the pouring of the inertia base concrete. Pass the anchor rod through the bushing, neoprene elements, and through a hole in the base pouring frame perimeter channel into the interior of the frame. Note: It is critical that the height of this channel hole be at the same elevation as the center of the hole in the angle bracket once the base is elevated and adjusted to the desired operating height. Lock the bushing into position against the outside of the pouring form channel using a jam nut on the interior surface of the base. At the interior end of the threaded base anchor rod, lock a washer between a pair of jam nuts per the enclosed product drawing.

After the base concrete has cured, raise the base into position so that it is fully supported by the isolators and

is at the required height. Carefully align the hole in the angle-mounting bracket with the base anchor rod. Position the angle bracket so that the face is 1/2" (13 mm) away from the side of the base. Mark the floor anchor bolt holes and drill and install the anchor bolts, double-checking that the base anchor rod is centered in all directions within the angle bracket hole. Note that all concrete anchors are to be installed in accordance with applicable building code standards. Typical anchor bolt requirements (to be reviewed and confirmed by others) are an embedment depth of eight (8) bolt diameters and a minimum of six (6) bolt diameters from the edge of the slab into which they are embedded.

Complete the assembly of the HS-5 angle bracket, bushing, and neoprene elements, referencing the enclosed drawing. Torque the base anchor rod nuts to the levels specified: 0.50" stud: 35 ft.-lb. 0.75" stud: 75 ft.-lb. 0.88" stud: 125 ft.-lb. 1.25" stud: 300 ft.-lb. Once installed, operate the restrained equipment through a complete turn-on, turn-off cycle to ensure that there is no contact between the anchor rod and the angle bracket at anytime during operation.

HS-5 Seismic Restraint I-P Units (inches and pounds)														Optional Weld		Optional Anchor	
Model	A	B	C	D	E	F	G	H	J	K	L	M	N	P	R	T	U (min.)
HS-5-01	6.00	6.00	6.00	0.38	1.00	4.00	1.50	3.00	3.00	0.50	3.00	0.50	2.50	0.13	2.00	0.28	3.00
HS-5-02	7.00	6.00	6.00	0.38	1.00	5.00	1.50	3.00	3.50	0.50	3.00	0.75	3.50	0.13	2.00	0.50	4.00
HS-5-03	9.00	6.00	6.00	0.50	1.00	7.00	1.75	3.00	4.50	0.50	3.50	0.88	4.00	0.25	2.75	0.63	5.00
HS-5-04	11.50	6.00	6.00	0.50	1.00	9.50	2.00	3.00	5.75	0.50	4.00	1.25	4.75	0.25	5.00	0.75	6.00
HS-5-05	15.00	8.00	6.00	0.50	1.50	12.00	2.00	3.00	7.50	0.50	4.25	1.25	6.00	0.25	5.00	1.00	8.00
HS-5-05A	15.00	8.00	6.00	0.50	1.50	12.00	2.00	3.00	7.50	0.50	4.25	1.25	9.00	0.25	6.00	1.00	9.00

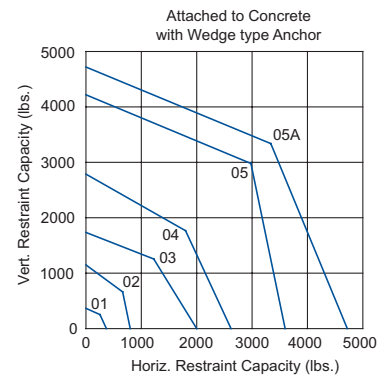
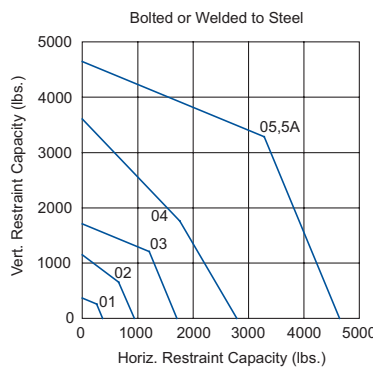
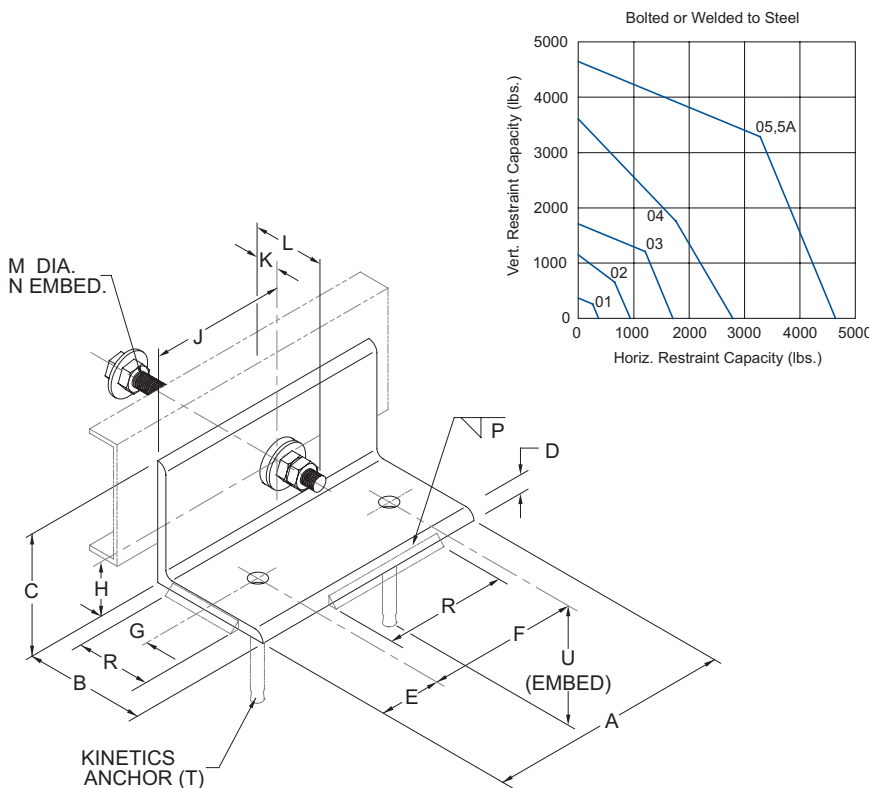

United States
 6300 Ireland Place
 P.O. Box 655
 Dublin, Ohio 43017
 Phone: 614-889-0480
 Fax: 614-889-0540

Canada
 1720 Meyerside Drive
 Mississauga, Ontario
 L5T 1A3
 Phone: 905-670-4922
 Fax: 905-670-1698

www.kineticsnoise.com
sales@kineticsnoise.com

Kinetics Noise Control, Inc. is continually upgrading the quality of our products. We reserve the right to make changes to this and all products without notice.