

# KINETICS™

## Seismic Snubber Model HS-2

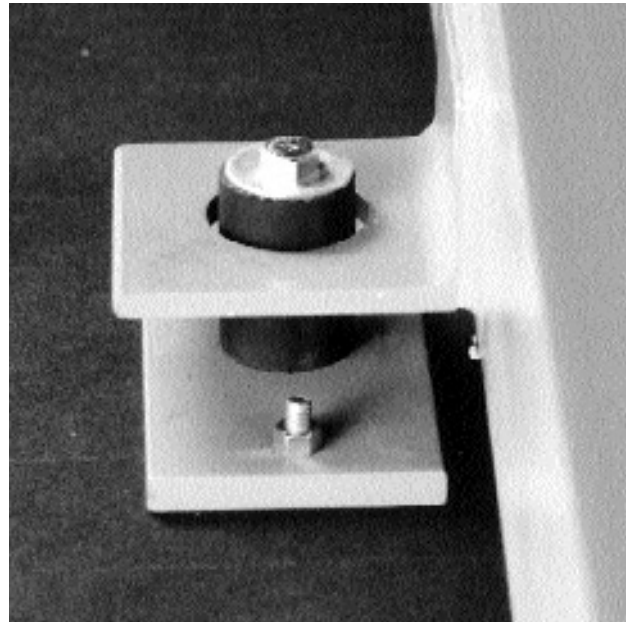

### Description

Model HS-2 Seismic Snubbers are designed for use in locations subject to earthquakes or other external forces which could displace resiliently supported equipment.

Snubbers, when anchored to the building structure and placed around vibration-isolated equipment, are intended to limit lateral motion by containing the supported equipment.

HS-2 Snubbers are designed to be used in pairs and will keep supported equipment contained when subjected to lateral forces from any direction. HS-2 Snubbers are not designed for use with high center-of-gravity supported equipment or where vertical forces must be considered.

Kinetics Model HS-2 Snubbers are heavy structural steel weldments designed to minimize equipment motion without failing. Resilient neoprene pads on the contact surface reduce shock loads by cushioning the impacts. Large diameter anchor bolt holes allow loads to be safely transferred to the building structure.

### Application

Building codes in many areas require building components to be capable of resisting forces created during a seismic event.

Equipment on resilient supports such as spring, neoprene or fiber glass vibration isolators can undergo large motions relative to the building during such an event.

By using properly spaced and designed resilient snubbers around the equipment, motion can be limited and equipment can remain in place.

Kinetics Model HS-2 Snubbers are rugged, heavy-duty products which have been designed to resist imposed forces from external sources, yet remain out of contact during normal operation so that vibration will not be transmitted to the building.

## Specifications

(Equipment) (Equipment Bases) (Concrete Inertia Bases) (Structural Lateral Supports) shall be restrained against excessive movement during a seismic event by the use of resilient snubbers designed to resist (0.1) (0.2) (0.25) (0.5) (0.75) (1.0) (1.5) (2.0)g loads, or to meet current building codes. The steel members of the snubbers shall be designed to yield but not fail under design conditions. Calculations by a registered Professional Engineer or certified test reports shall be submitted which verify the capacity of each snubber.

Snubbers shall be welded steel and shall be attached to the building structure in a manner consistent with anticipated loads and shall meet current building codes.

Snubbers shall be placed around equipment as shown on drawings to limit lateral movement at each snubber to 1/8" (3 mm). A minimum of two snubbers shall be installed around each resiliently supported piece of equipment.

Snubbers shall include resilient pads to cushion any impact and shall be installed so as to be free of contact during equipment operation.

Snubbers shall be Model HS-2 by Kinetics Noise Control, Inc., Dublin, Ohio.

## HS-2 Installation Instructions

The Kinetics Model HS-2 Snubber is to be installed such that the resilient surface of the floor-mounted post will contact the interior surface of the base-mounted restraint bracket once the equipment has been displaced approximately 1/8" (3 mm) in any lateral direction. Because each HS-2 can handle horizontal loads in any direction, some applications involving equipment with low centers of gravity may require only two restraints. However, variations in the horizontal center of gravity location or the physical size of the supported equipment may make the use of additional restraints necessary.

The precise location of the Snubber is either as indicated on drawings or, in lieu of drawings, should be as follows: In instances where two restraints are used, they should be located at the midpoint of the long axis of the equipment base. In the case of four restraints, they should be located either as close to the corners as possible or at the midpoint of each side.

The Snubber should be fitted only after the isolated equipment is mounted, piped and ready for operation. The post should then be set on the floor in its approximate mounting location. The restraint bracket should then be placed over the post with the specified gap between the underside of the bracket and the floor. It should then be welded to the side of the base.

With the equipment operating, center the post in the clearance hole in the restraint bracket and then either weld or bolt it to the floor structure. Bolts should be through bolts and should connect to structural steel capable of withstanding the maximum loads that can be generated by the restrained equipment. Anchors are to be installed in accordance with applicable code standards.

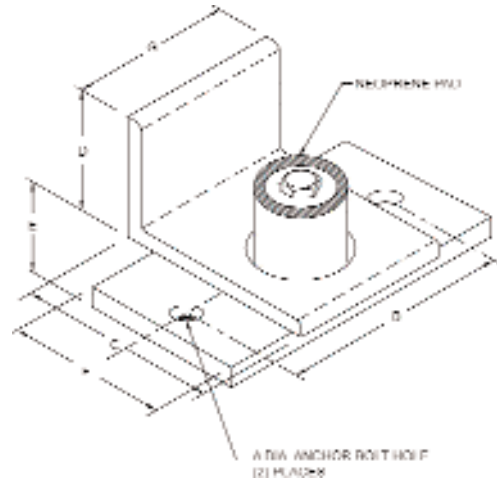

		LATERAL LOAD RATING No Vertical Load		DIMENSIONS						
		Capacity with through bolts	Capacity with anchors	A	B	C	D	E	F	G
English Units	Model									
	HS 2-2000	1624 lbs.	945 lbs.	0.44"	6.00"	5.00"	3.00"	1.25"	4.00"	4.50"
	HS 2-4000	2887 lbs.	1308 lbs.	0.56"	6.00"	5.00"	3.00"	1.25"	4.00"	4.50"
	HS 2-6000	4300 lbs.	1677 lbs.	0.69"	7.50"	6.00"	4.00"	2.00"	5.00"	6.00"
	HS 2-8000	6966 lbs.	3354 lbs.	0.94"	10.50"	6.00"	4.00"	2.00"	5.00"	8.00"
Metric Units	HS 2-2000	738 kg	430 kg	11 mm	152 mm	127 mm	76 mm	32 mm	102 mm	114 mm
	HS 2-4000	1312 kg	595 kg	14 mm	152 mm	127 mm	76 mm	32 mm	102 mm	114 mm
	HS 2-6000	1954 kg	762 kg	18 mm	191 mm	152 mm	102 mm	51 mm	127 mm	152 mm
	HS 2-8000	3166 kg	1524 kg	24 mm	267 mm	152 mm	102 mm	51 mm	127 mm	203 mm



United States  
6300 Ireland Place  
P.O. Box 655  
Dublin, Ohio 43017  
Phone: 614-889-0480  
Fax: 614-889-0540

Canada  
1720 Meyerside Drive  
Mississauga, Ontario  
L5T 1A3  
Phone: 905-670-4922  
Fax: 905-670-1698

[www.kineticsnoise.com](http://www.kineticsnoise.com)  
[sales@kineticsnoise.com](mailto:sales@kineticsnoise.com)

Kinetics Noise Control, Inc. is continually upgrading the quality of our products. We reserve the right to make changes to this and all products without notice.