

# KINETICS™

## Seismic Snubber Model HS-1



### Description

Model HS-1 Seismic Snubbers are designed for use in locations subject to earthquakes and other external forces which could displace resiliently supported equipment.

Snubbers, when anchored to the building structure and placed around vibration-isolated equipment, are intended to limit motion by containing the supported equipment.

HS-1 Snubbers are designed to be used in a minimum quantity of four and will keep supported equipment contained when subjected to lateral forces from any direction. HS-1 Snubbers are not designed for use with high center-of-gravity supported equipment or where vertical forces must be considered.

Kinetics Model HS-1 Snubbers are heavy structural steel weldments designed to minimize equipment motion. A resilient neoprene pad on the contact surface reduces shock loads by cushioning the impacts. Large diameter anchor bolt holes allow loads to be safely transferred to the building structure.

### Application

Building codes in many areas require building components to be capable of resisting forces created during a seismic event.

Equipment on resilient supports such as spring, neoprene or fiberglass vibration isolators can undergo large motions relative to the building during such an event. By using properly spaced and designed resilient snubbers around the equipment, motion can be limited and equipment can remain in place.

Kinetics Model HS-1 Snubbers are rugged, heavy-duty products which have been designed to resist imposed forces from external sources, yet remain out of contact during normal operation so that vibration will not be transmitted to the building.

## Specifications

(Equipment) (Equipment Bases) (Concrete Inertia Bases) (Structural Steel Supports) shall be restrained against excessive lateral movement during a seismic event by the use of resilient snubbers designed to resist (0.1) (0.2) (0.25) (0.5) (0.75) (1.0) (1.5) (2.0)g loads, or to meet current building codes. The steel members of the snubbers shall be designed to yield but not fail under design conditions. Calculations by a registered Professional Engineer or certified test reports shall be submitted which verify the capacity of each snubber.

Snubbers shall be welded steel and shall be attached to the building structure in a manner consistent with anticipated loads and shall meet current building codes.

Snubbers shall be placed around equipment as shown on drawings to limit lateral movement at each snubber to 1/4" (6 mm). A minimum of (4) snubbers shall be installed around each resiliently supported piece of equipment.

Snubbers shall include a resilient pad to cushion any impact and shall be installed so as to be free of contact during equipment operation.

Snubbers shall be Model HS-1 by Kinetics Noise Control, Inc., Dublin, Ohio.

## HS-1 Installation Instructions

The Kinetics Model HS-1 Snubber is a single-axis, single-direction restraint designed to restrict the lateral motion which results from external loads acting on resiliently mounted equipment. The Kinetics Model HS-1 Snubber is to be installed such that the resilient surface will contact a vertical surface on the side of the equipment or base once the equipment has been displaced approximately 1/4" (6 mm) in any lateral direction.

A minimum of four HS-1 Snubbers are required on a given installation. These are to be installed at 90 degrees to one another to ensure that there is no lateral direction in which the equipment can move without contacting at least one Snubber.

The precise location of the Snubber is either as indicated on the drawings or, in lieu of drawings, to be on the supported system's center of gravity.

The Snubber should be fitted only after the isolated equipment is mounted, piped and operating. The Snubber should be located with its face 1/4" (6 mm) clear of the equipment. Attachment points should be marked, drilled and bolts or anchors fitted. Bolts, if used, should be through bolts and should connect to structural steel capable of withstanding the maximum loads that can be generated by the restrained equipment. Anchors should be installed in accordance with applicable code standards.

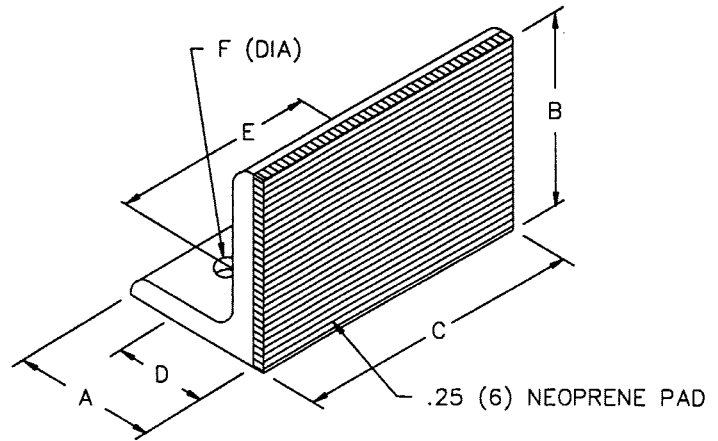

		LATERAL LOAD RATING No Vertical Load		DIMENSIONS					
		Capacity with through bolts	Capacity with anchors	A	B	C	D	E	F
English Units	HS 1-2000	2423 lbs.	1228 lbs.	4.00"	3.00"	8.00"	1.50"	6.00"	0.56"
	HS 1-4000	4600 lbs.	2160 lbs.	6.00"	4.00"	9.50"	2.00"	7.50"	0.69"
	HS 1-6000	6215 lbs.	3146 lbs.	6.00"	4.00"	12.00"	2.00"	9.00"	0.81"
Metric Units	HS 1-2000	1101 kg	558 kg	102 mm	76 mm	203 mm	38 mm	152 mm	14 mm
	HS 1-4000	2091 kg	982 kg	152 mm	102 mm	241 mm	51 mm	191 mm	18 mm
	HS 1-6000	2825 kg	1430 kg	152 mm	102 mm	305 mm	51 mm	229 mm	21 mm



United States  
6300 Ireland Place  
P.O. Box 655  
Dublin, Ohio 43017  
Phone: 614-889-0480  
Fax: 614-889-0540

Canada  
1720 Meyerside Drive  
Mississauga, Ontario  
L5T 1A3  
Phone: 905-670-4922  
Fax: 905-670-1698

[www.kineticsnoise.com](http://www.kineticsnoise.com)  
[sales@kineticsnoise.com](mailto:sales@kineticsnoise.com)

Kinetics Noise Control, Inc. is continually upgrading the quality of our products. We reserve the right to make changes to this and all products without notice.