



MODEL KSCH SUPER-COMPACT CEILING HANGER

SELECTION GUIDELINES

IMPORTANT! PLEASE READ FIRST:

These suggested selection guidelines represent generally accepted procedures for properly selecting Kinetics Noise Control Model KSCH Super-Compact Ceiling Hanger for ceiling system isolation. These suggestions may be followed, modified, or rejected by the owner, engineer, contractor, and/or their respective representative(s) since they, not Kinetics Noise Control, are responsible for planning and executing procedures appropriate to a specific application. Kinetics Noise Control reserves the right to alter these suggestions and encourages contact with the factory or its representatives to review any possible modification to these suggested guidelines prior to commencing selection.

1. Define ceiling area being isolated and sketch a layout showing the ceiling hanger locations per the following criteria (refer to layout diagram below):
 - A. Isolators installed at the perimeter must be located not more than 16" from the edge of the isolated ceiling; maintain at least a three-inch clearance from the perimeter.
 - B. Isolators may be located up to 48" along the perimeter of the isolated ceiling.
 - C. Isolators mounted mid-room (i.e., those isolators not at the perimeter) may be located up to 48" on center each way (o.c.e.w.).
 - D. Many room configurations will require non-conventional placement of isolation hangers to support the gypsum board ceiling (i.e., every isolated ceiling cannot be laid out in even rows in each direction). Consideration must be given to supporting the gypsum board ceiling adequately; this may require unique spacing arrangements to accommodate installation of the ceiling grid.
2. Once spacing of the ceiling hangers is determined and sketched, three (3) general areas of the ceiling require load calculations: mid-room, along the perimeter, and in the corners. The total number of calculations required depends on how varied the spacing of the hangers is in each of these areas.
3. Determine the total weight of the layers of gypsum wallboard and ceiling grid components being supported by the isolation hangers. The chart below is useful in determining common weights for materials used in isolated ceiling construction:

Building Material	Weight (psf)
R11 (3-1/2" Fiberglass)	0.50
1-1/2" CRC and 7/8" DWF	0.50
1/2" Gypsum Board (Type X)	1.90
5/8" Gypsum Board (Type X)	2.33



4. Additional items such as lights or a lay-in tile ceiling may be suspended from the gypsum board/ceiling grid assembly. The weight of these items needs to be considered when determining the appropriate number/capacity of hangers required.

5. Calculate load at each hanger location:

$$\text{_____ lbs/hanger} = \text{Total PSF of ceiling materials} \times \text{SF area carried by hanger}$$

Where, PSF = pounds per square foot

SF = square feet

6. Select appropriate hanger for each location from chart below. Designated model numbers indicate the load at which the isolator deflects 1/2" (nominal). Every hanger has at least a 50% overload capacity; it is possible to slightly exceed the maximum capacity shown in the chart below:

Model KSCH	Spring Color	Capacity Range (lbs.)	Deflection Range (in.)
30	Blue	21-44	0.32-0.70
60	Gray	35-66	0.32-0.62
100	Silver	70-111	0.32-0.51
140	Green	100-141	0.32-0.45



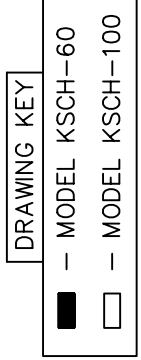
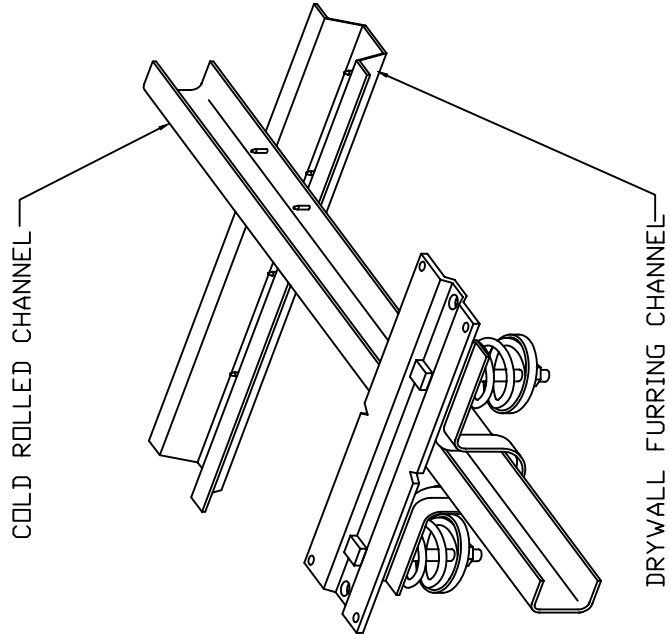
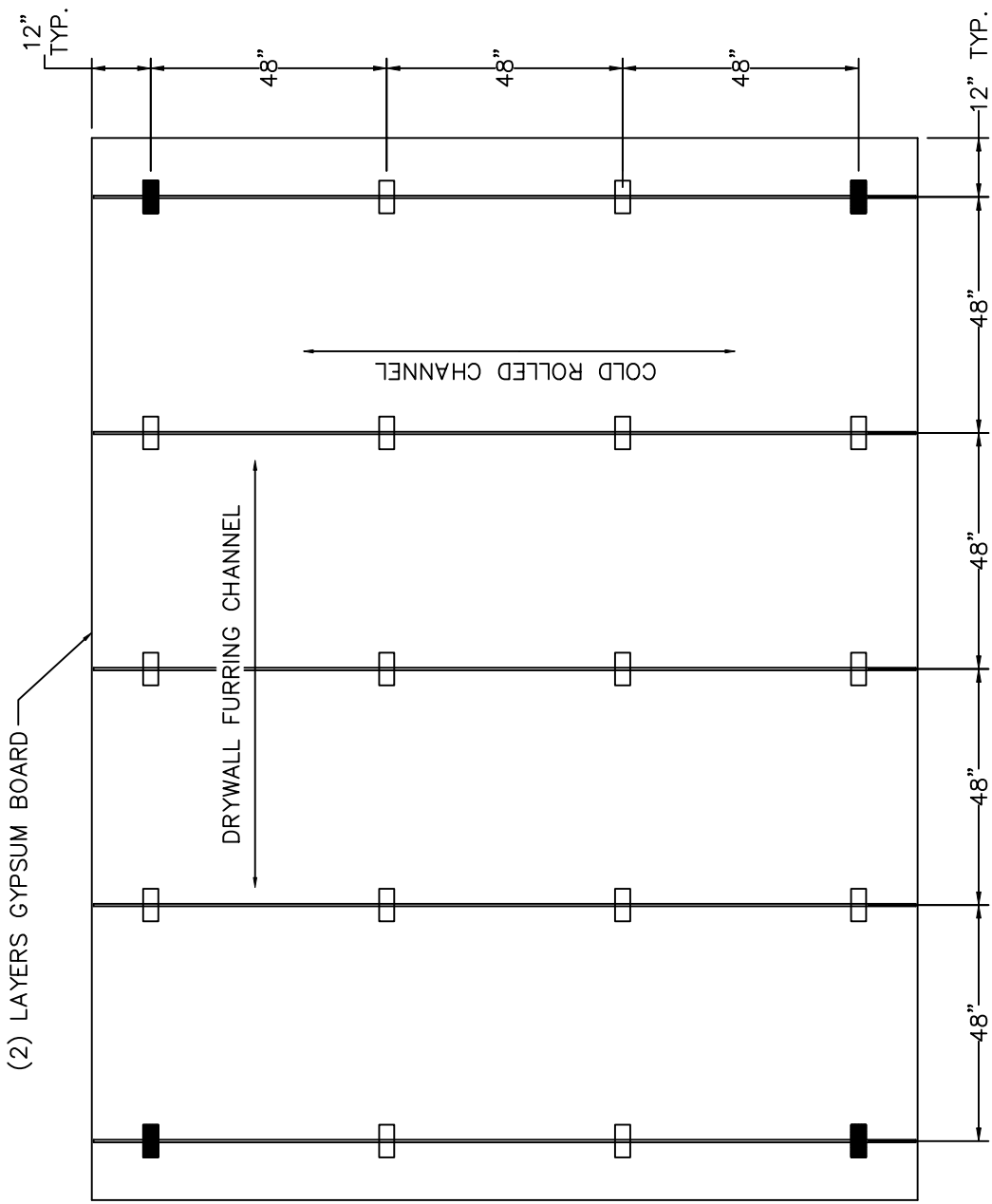

NOTES:

- 1.) NO CHANNEL SHALL CONTACT PERIMETER AND CREATE A SHORT-CIRCUIT.
- 2.) ATTACH TWO (2) LAYERS OF 5/8" THICK TYPE "X" GYPSUM BOARD TO DWF.
- 3.) SEAL EDGES W/ RESILIENT NON-HARDENING CAULK.
- 4.) ISOLATED CEILING CANNOT BE RIGIDLY ATTACHED TO ANY NON-ISOLATED STRUCTURE.

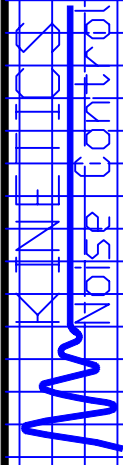

TITLE
 TYPICAL CEILING
 HANGER LAYOUT
 MODEL KSCH

LAST DATE
 REVISED
 10/31/03

DRAWN BY
 TEF

DRAWING NO.
 DIAGRAM "A"