

Super-Compact Ceiling Hanger

Model KSCH

Reg. U.S. Patent No. 7,028,432



Ceiling Isolation Theory:

Resiliently suspended ceiling systems are designed to minimize floor impact noise and airborne sound transmissions through the floor/ceiling structure. Creating airspace and resiliently decoupling the mass of the isolated ceiling from the non-isolated structure can effectively control noise transmission. Kinetics Noise Control ceiling isolation products use various types of resilient decouplers including springs, rubber or fiberglass pads, and combinations of pads and springs to improve Sound Transmission Class (STC) and Impact Insulation Class (IIC) values.

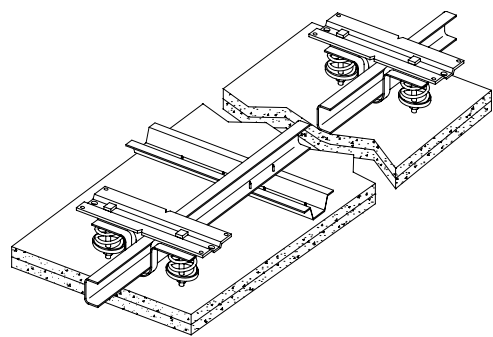

Application:

Low-profile isolated ceiling construction using a resilient hanger assembly to support one or more layers of gypsum board is desired by architects wanting to minimize ceiling drop in an occupied space. The Model KSCH Super-Compact Ceiling Hanger helps the designer achieve the goal of resiliently decoupling the ceiling using less than three and one half (3-1/2) inches of space. Model KSCH is designed to allow use of a single piece of 1-1/2" x 1/2" cold-rolled channel to support the drywall furring channel to which the gypsum board is attached. Renovation and new-build design ceiling height concerns are addressed easily with Model KSCH.

Benefits:

- Low 3-1/2" airspace using 7/8" drywall furring channel at 1/2" nominal spring deflection.
- Maximum natural frequency of 5.5 Hz under lightest typical load conditions.
- Requires only one (1) piece of 1-1/2" x 1/2" cold-rolled channel.
- Extended mounting bracket allows easy attachment to non-isolated deck.
- Centering notches for flawless alignment.
- Minimal vertical/lateral movement during a seismic event.
- STC 72, IIC 51 with two (2) layers gypsum board suspended under a 6" concrete slab (75 psf) with 1-1/2" fiberglass batt in airspace - 1/2" deflection springs.
- Also available with 1" deflection springs - increases size of airspace.

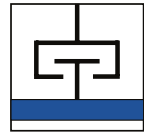

Model KSCH Super-Compact Ceiling Hanger

Specifications

Part 1 - General

1.01 Work Included

A. Furnish all labor, materials, tools, and equipment; and, perform all operations necessary for the installation of resiliently suspended ceilings shown on contract drawings.

1.02 System Description

A. Resiliently suspended gypsum ceilings, where shown on drawings, shall be isolated from the building structure to reduce airborne sound and impact noise transmission.

1.03 Quality Assurance

A. The resilient isolation hangers and perimeter isolation material shall be designed and fabricated at the facilities of a nationally recognized manufacturer having a minimum of five years experience in furnishing similar materials.

1.04 Submittals

A. Product performance data shall be submitted to the designer for review and shall include an Airborne Sound Transmission Loss Test Report and an Impact Sound Transmission Loss Test Report for measurements conducted in accordance with ASTM E90-90 and ASTM E492-90, respectively. Test reports shall document a minimum STC 72 and IIC 51 for a resiliently suspended ceiling attached below a six-inch thick concrete slab without finish flooring and that consists of two layers of 5/8" thick gypsum board with 1-1/2" thick fiberglass batt in the cavity between the concrete slab and the top layer of gypsum board. Sound and impact test reports shall be from an independent laboratory.

Part 2 - Products

2.01 Materials

A. The sound isolation materials specified herein shall be designed and manufactured by Kinetics Noise Control, Inc. Dublin, Ohio.

B. Ceilings shall be supported by Model KSCH Super-Compact Ceiling Hangers. Resilient hangers shall have sufficient capacity to sustain continuously applied ceiling weight without settling after initial deflection.

C. The isolation hanger shall incorporate two 1/2" deflection steel springs operating in parallel with each other; and shall provide 50% overload capacity. Each spring shall operate in series with a resilient, molded neoprene noise and vibration isolation pad. The two springs and neoprene pads shall be incorporated into a stamped steel hanger assembly which supports the isolated ceiling.

D. The hanger assembly bracket shall be designed to accept 1-1/2" x 1/2", 16-gage cold-rolled steel. The isolation hanger deflection shall be selected by the manufacturer to provide a maximum natural frequency of 5.5 Hz. The steel spring element shall have a minimum Kx to Ky of 1 at its 1/2" rated deflection.

E. Resiliently suspended ceilings shall be separated where non-isolated building components abut. Isolation material shall be 3/8" thick Model SRP perimeter isolation board. Model SRP shall not be penetrated by nail, screw, or similar fastener. Model SRP shall be adhered to non-isolated structure. Resiliently suspended ceiling shall be constructed against Model SRP. Model SRP shall be sealed using resilient, non-hardening caulk.

Part 3 - Execution

3.01 Installation

A. The installation of all sound isolation materials specified herein, including those installed under other sections of the specifications, shall be in accordance with procedures submitted by the isolation material manufacturer, and approved by the Architect.

B. All building components supported by the isolation hangers shall be free from rigid contact with any part of the non-isolated building structure to prevent unwanted sound flanking.



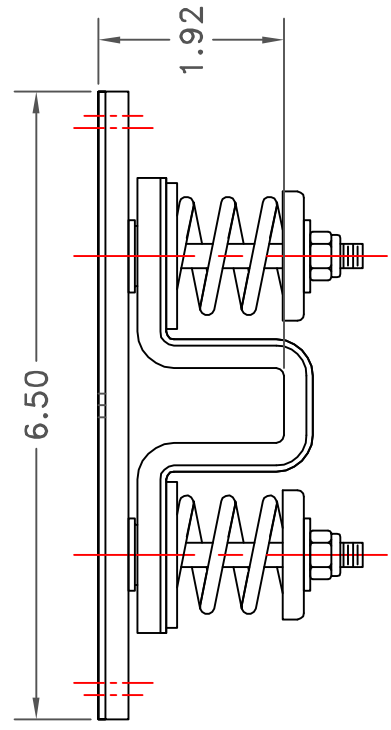
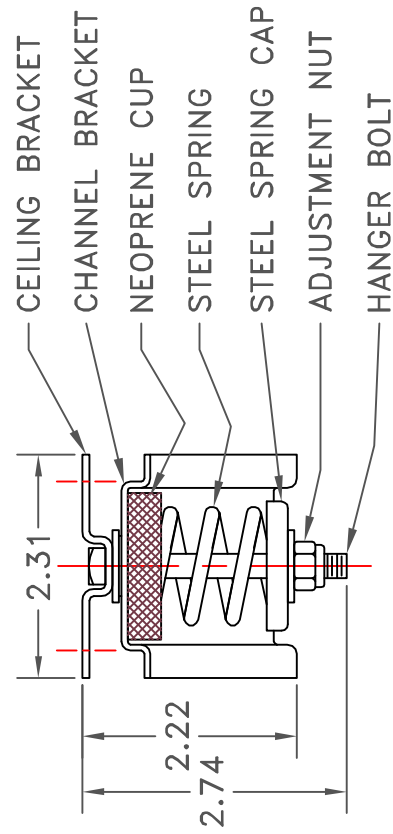
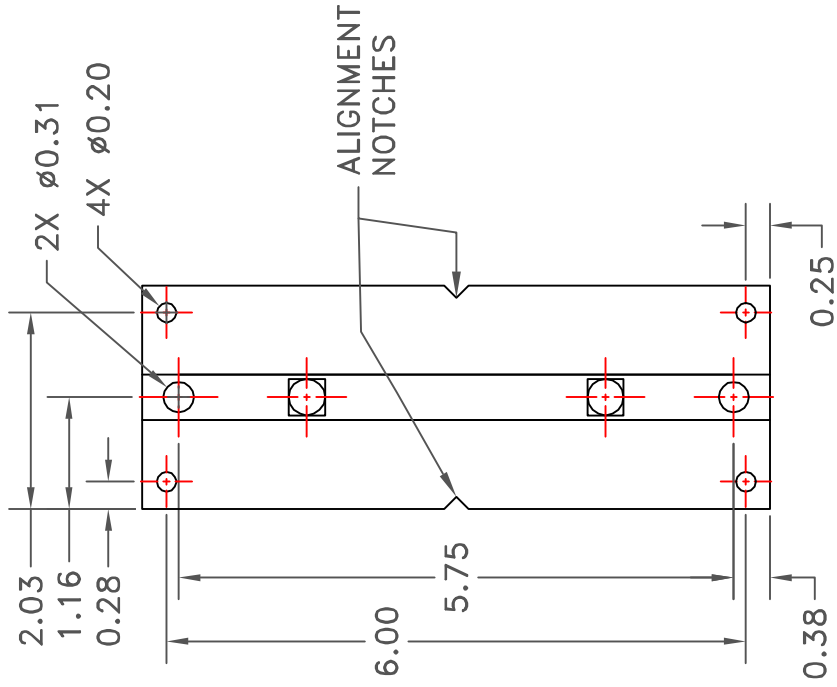

MODEL	SPRING COLOR	LOAD		RATED	
		LB	KG	IN	MM
KSCH-30	BLUE	32.00	14.5	0.50	13
KSCH-60	GRAY	60.00	27.2	0.56	14
KSCH-100	SILVER	100.00	45.4	0.46	12
KSCH-140	GREEN	144.00	65.3	0.46	12

KSCH ISOLATION HANGERS HAVE A TYPICAL OVERLOAD CAPACITY OF 50%

KSCH ISOLATION HANGERS HAVE A MINIMUM K_x/K_y OF 1.2

KSCH HANGER BRACKETS WILL CARRY (5) TIMES OVERLOAD WITHOUT FAILURE

KSCH HANGER BRACKETS ARE ELECTRO ZINC PLATED

KSCH SPRING COILS ARE POWDER COATED



MODEL KSCH SUPER-COMPACT CEILING HANGER

SELECTION GUIDELINES

IMPORTANT! PLEASE READ FIRST:

These suggested selection guidelines represent generally accepted procedures for properly selecting Kinetics Noise Control Model KSCH Super-Compact Ceiling Hanger for ceiling system isolation. These suggestions may be followed, modified, or rejected by the owner, engineer, contractor, and/or their respective representative(s) since they, not Kinetics Noise Control, are responsible for planning and executing procedures appropriate to a specific application. Kinetics Noise Control reserves the right to alter these suggestions and encourages contact with the factory or its representatives to review any possible modification to these suggested guidelines prior to commencing selection.

1. Define ceiling area being isolated and sketch a layout showing the ceiling hanger locations per the following criteria (refer to layout diagram below):
 - A. Isolators installed at the perimeter must be located not more than 16" from the edge of the isolated ceiling; maintain at least a three-inch clearance from the perimeter.
 - B. Isolators may be located up to 48" along the perimeter of the isolated ceiling.
 - C. Isolators mounted mid-room (i.e., those isolators not at the perimeter) may be located up to 48" on center each way (o.c.e.w.).
 - D. Many room configurations will require non-conventional placement of isolation hangers to support the gypsum board ceiling (i.e., every isolated ceiling cannot be laid out in even rows in each direction). Consideration must be given to supporting the gypsum board ceiling adequately; this may require unique spacing arrangements to accommodate installation of the ceiling grid.
2. Once spacing of the ceiling hangers is determined and sketched, three (3) general areas of the ceiling require load calculations: mid-room, along the perimeter, and in the corners. The total number of calculations required depends on how varied the spacing of the hangers is in each of these areas.
3. Determine the total weight of the layers of gypsum wallboard and ceiling grid components being supported by the isolation hangers. The chart below is useful in determining common weights for materials used in isolated ceiling construction:

Building Material	Weight (psf)
R11 (3-1/2" Fiberglass)	0.50
1-1/2" CRC and 7/8" DWF	0.50
1/2" Gypsum Board (Type X)	1.90
5/8" Gypsum Board (Type X)	2.33



4. Additional items such as lights or a lay-in tile ceiling may be suspended from the gypsum board/ceiling grid assembly. The weight of these items needs to be considered when determining the appropriate number/capacity of hangers required.

5. Calculate load at each hanger location:

$$\text{_____ lbs/hanger} = \text{Total PSF of ceiling materials} \times \text{SF area carried by hanger}$$

Where, PSF = pounds per square foot

SF = square feet

6. Select appropriate hanger for each location from chart below. Designated model numbers indicate the load at which the isolator deflects 1/2" (nominal). Every hanger has at least a 50% overload capacity; it is possible to slightly exceed the maximum capacity shown in the chart below:

Model KSCH	Spring Color	Capacity Range (lbs.)	Deflection Range (in.)
30	Blue	21-44	0.32-0.70
60	Gray	35-66	0.32-0.62
100	Silver	70-111	0.32-0.51
140	Green	100-141	0.32-0.45



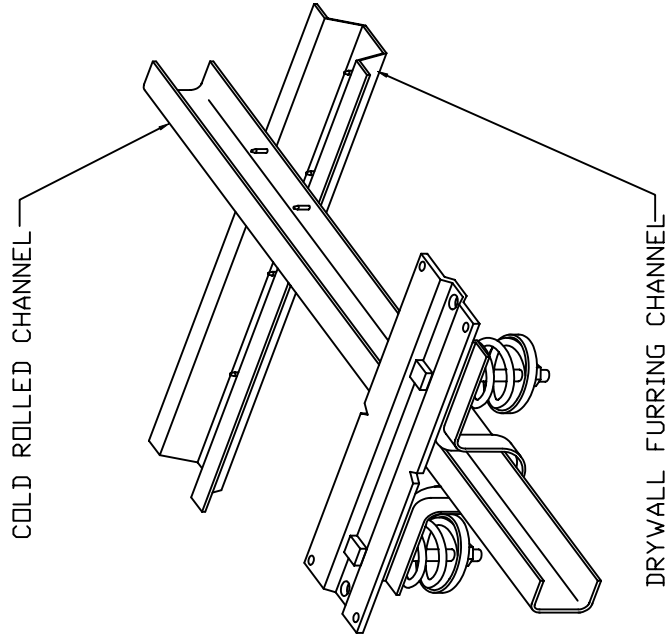
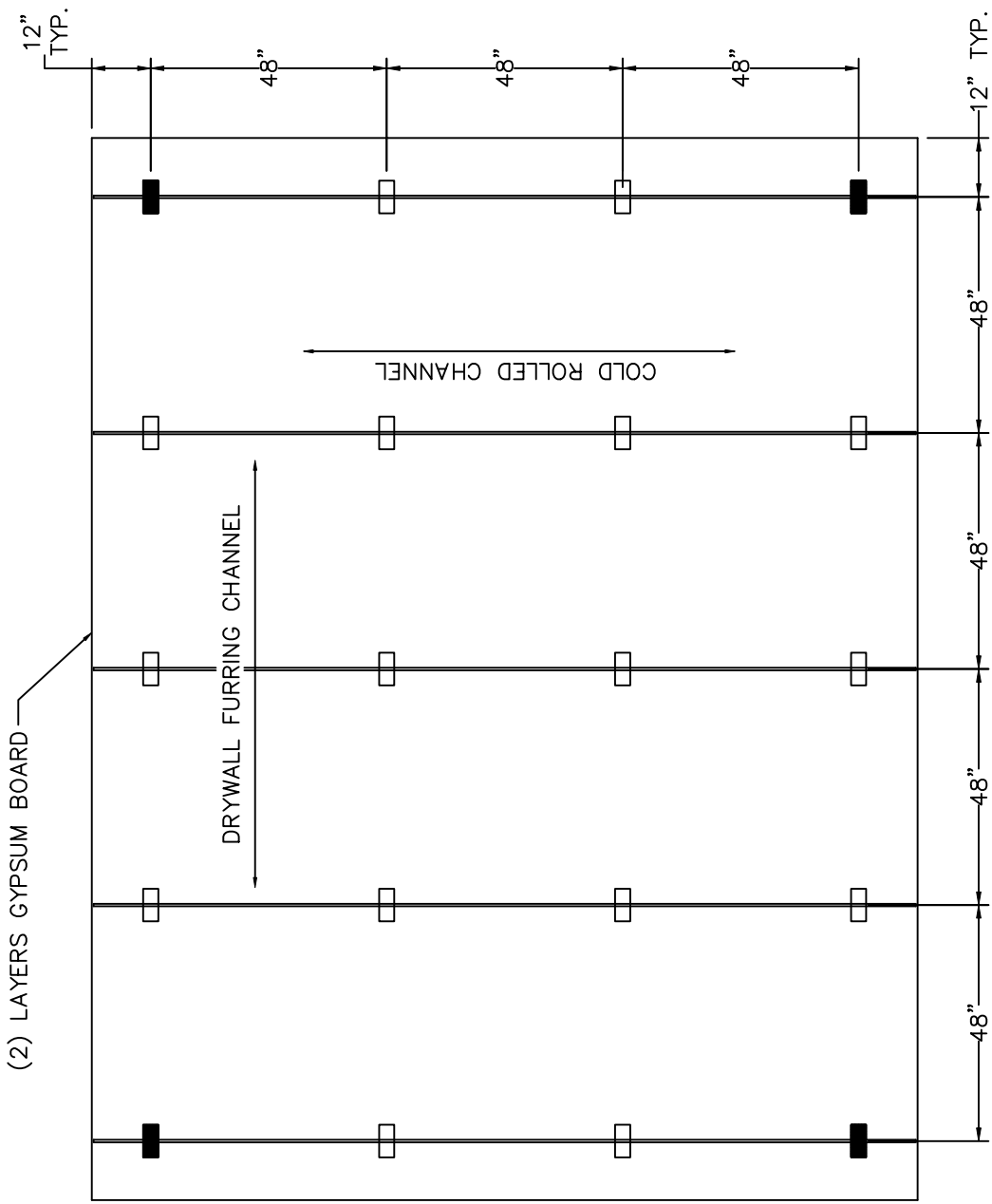

NOTES:

- 1.) NO CHANNEL SHALL CONTACT PERIMETER AND CREATE A SHORT-CIRCUIT.
- 2.) ATTACH TWO (2) LAYERS OF 5/8" THICK TYPE "X" GYPSUM BOARD TO DWF.
- 3.) SEAL EDGES W/ RESILIENT NON-HARDENING CAULK.
- 4.) ISOLATED CEILING CANNOT BE RIGIDLY ATTACHED TO ANY NON-ISOLATED STRUCTURE.

DRAWING KEY

- - MODEL KSCH-60
- - MODEL KSCH-100

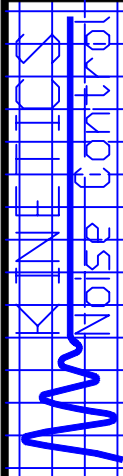

TITLE
 TYPICAL CEILING
 HANGER LAYOUT
 MODEL KSCH

LAST DATE
 REVISED
 10/31/03

DRAWN BY
 TEF

DRAWING NO.
 DIAGRAM "A"



MODEL KSCH SUPER-COMPACT CEILING HANGER

INSTALLATION GUIDELINES

IMPORTANT! PLEASE READ FIRST:

These suggested installation guidelines represent generally accepted procedures for successful installation of Kinetics Noise Control Model KSCH Super-Compact Ceiling Hanger for ceiling system isolation. These suggestions may be followed, modified, or rejected by the owner, engineer, contractor, and/or their respective representative(s) since they, not Kinetics Noise Control, are responsible for planning and executing procedures appropriate to a specific application. Kinetics Noise Control reserves the right to alter these suggestions and encourages contact with the factory or its representatives to review any possible modification to these suggested guidelines prior to commencing installation.

1. Installation of an isolated ceiling system that uses Kinetics Noise Control Model KSCH Super-Compact Ceiling Hangers requires the following materials (as specified by others and purchased separately):

- A. 1-1/2" x 1/2", 16-gage cold-rolled channel.
- B. 7/8" 20- to 25-gage drywall furring channel.
- C. Anchors for mounting into non-isolated ceiling substrate.
- D. 1/2" or 5/8" thick gypsum board (Type X).
- E. Appropriate tools and equipment for installation.

Please note: If submittal drawings have been prepared for the installation, review drawings for completeness and accuracy; otherwise, refer to Selection Guidelines for selecting ceiling hangers.

2. Mark grid pattern on existing non-isolated ceiling using the following spacing criteria:

- A. Isolators installed at the perimeter must be located not more than 16" from the edge of the isolated ceiling; maintain at least a three-inch clearance from the perimeter.
- B. Isolators may be located up to 48" along the perimeter of the isolated ceiling.
- C. Isolators mounted mid-room (i.e., those isolators not at the perimeter) may be located up to 48" on center each way (o.c.e.w).

Please note: Submittal drawings, if provided, override general location guidelines provided above.

3. Remove Model KSCH Super-Compact Ceiling Hangers from box. **Do not disassemble mounting bracket from unit for installation purposes.** Confirm capacity of isolator to ensure proper location in grid (see chart). If provided, submittal drawings will identify location of



specific hanger by capacity rating. Slide cold-rolled channel through the channel carrier of the isolator. After determining the direction the cold-roll channel will run, locate the isolators at the intersect points on the grid. Use the locating notches and anchor holes on the mounting bracket to align the isolators properly. Anchor isolators to non-isolated ceiling using appropriate fastener at minimum of two (2) locations through the mounting bracket. Position the cold-rolled channel to prevent contact at partition/wall/column or any other non-isolated structural component. Inter-connect ends of cold-rolled channel using appropriate practices for ceiling grid installation.

Model KSCH	Spring Color	Capacity Range (lbs.)	Deflection Range (in.)
30	Blue	21-44	0.32-0.70
60	Gray	35-66	0.32-0.62
100	Silver	70-111	0.32-0.51
140	Green	100-141	0.32-0.45

4. Attach drywall furring channel to cold-rolled steel and interconnect the ends of the furring channel using appropriate practices for ceiling grid installation. Furring channel cannot contact non-isolated structural components. Make certain cold-rolled channel is resting on the bottom of the channel carrier bracket and not contacting the mounting bracket.

5. After assembling the ceiling grid, check for levelness. By loosening or tightening the nuts on the leveling bolts, the grid adjusts up to 1/4". Shim between the decking and mounting bracket if additional adjustment is required (this may require removal of some of the isolators). Do not bend or twist mounting bracket when shimming and leveling isolator.

6. Install Model SRP perimeter isolation board at partitions/walls, columns, and around any non-isolated building components to create a 3/8" wide resilient layer that ensures the isolated ceiling remains decoupled from the non-isolated structure. As the gypsum board is attached to the grid, the springs will compress (up to 3/4") allowing the ceiling system to lower into final position. Position the Model SRP to account for this change to final elevation. Trimming the Model SRP may be required following installation of the gypsum board. If an alternate method for ensuring that the isolated ceiling remains decoupled is employed (e.g., using resilient backer rod), be sure to maintain a 3/8" gap from non-isolated structural components.

7. Install the gypsum board using accepted practices for attaching to the grid system. Be certain to maintain a 3/8" gap between non-isolated structural components and the isolated ceiling to ensure that the gypsum board does not contact any non-isolated structural components. Do not allow gypsum board to rest on top edge of Model SRP; it should abut the perimeter isolation board. Do not allow the Model SRP to become compressed against the non-isolated structure. In some cases, additional adjustment of the gypsum board may be necessary to achieve levelness, consult factory for procedures.

8. Trim Model SRP as required and caulk gap using a resilient, non-hardening caulk.

