



UL Online Certifications Directory

XHBN.HW-D-0031 Joint Systems

Page Bottom

Joint Systems

[See General Information for Joint Systems](#)

System No. HW-D-0031

March 31, 2006

Assembly Rating — 2 Hr

L Rating At Ambient — Less Than 1 CFM/Lin Ft

L Rating At 400 F — Less Than 1 CFM/Lin Ft

Nominal Joint Width — 2 In.

Class II Movement Capabilities — 25% Compression Or Extension

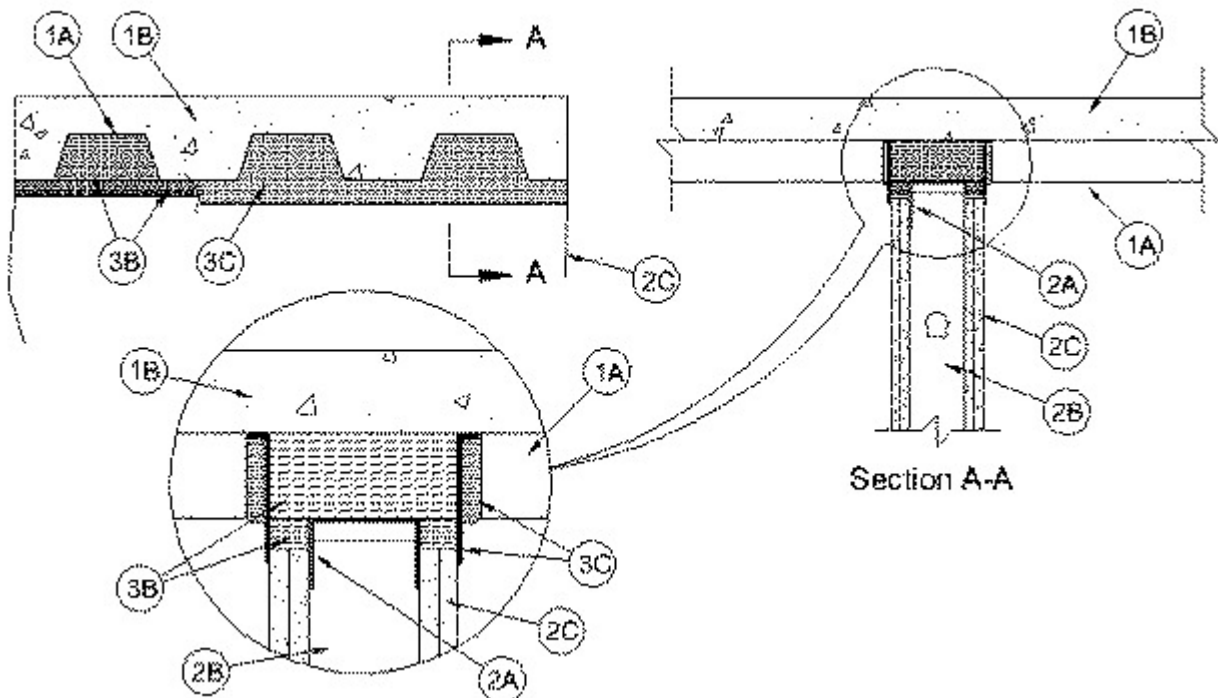

1. **Floor Assembly** — The fire-rated fluted steel deck/concrete floor assembly shall be constructed of the materials and in the manner described in the individual D700 or D900 Series Floor-Ceiling Design in the UL Fire Resistance Directory and shall include the following construction features:

A. **Steel Floor And Form Units*** — Max 3 in. (76 mm) deep galv steel fluted floor deck .

B. Concrete — Min 2-1/2 in. (64 mm) thick reinforced concrete, as measured from the top plane of the floor units.

C. Spray Applied Fire Resistive Material* — (Optional, Not Shown) — Prior to the installation of the Deflection Channel, Forming Material and Fill, Void or Cavity Materials (Items 3A, 3B, 3C), the steel floor units may be sprayed with a min 5/16 in. (8 mm) to max 11/16 in. (18 mm) thickness of fire resistive material.

W R GRACE & CO - CONN

CONSTRUCTION PRODUCTS DIV — Type MK-6/HT.

1A. Roof Assembly — (Not Shown)—As an alternate to the floor assembly, a fire rated fluted steel deck roof assembly may be used. The roof assembly shall be constructed of the materials and in the manner described in the individual P900 Series Roof-Ceiling Design in the UL Fire Resistance Directory. **The hourly rating of the roof assembly shall be equal to or greater than the hourly rating of the wall assembly.** The roof assembly shall include the following construction features:

A. Steel Roof Deck — Max 3 in. (76 mm) deep galv steel fluted roof deck.

B. Roof Insulation — Min 2-1/4 in. (57 mm) thick poured insulating concrete, as measured from the top plane of the roof deck.

2. Wall Assembly — The 2 hr fire rated gypsum board/steel stud wall assembly shall be constructed of the materials and in the manner described in the individual U400- or V400 Series Wall and Partition Design in the UL Fire Resistance Directory and shall include the following construction features:

A. Steel Floor And Ceiling Runners — Floor and ceiling runners of wall assembly shall consist of galv steel channels sized to accommodate steel studs (Item 2B). When deflection channel (Item 3A) is used, ceiling runner to be provided with 3 in. (76 mm) flanges. Ceiling runner is installed within the deflection channel with 2 in. (51 mm) gap maintained between the top of ceiling runner and top of deflection channel. When deflection channel is not used, flange height of ceiling runner shall be min 3/4 in. (19 mm) greater than nom joint width. Ceiling runner installed perpendicular to direction of fluted steel deck and secured to valleys with steel masonry anchors or by welds spaced max 24 in. (610 mm) OC. When optional spray-applied fire resistive material is used on the steel deck and when deflection channel is not used, ceiling runner secured through spray-applied material to each valley of the steel deck with min 3/16 in. (5 mm) diam steel masonry anchors spaced max 12 in. (305 mm) OC.

A1. Light Gauge Framing*- Slotted Ceiling Runner — As an alternate to the ceiling runner in Item 2A, slotted ceiling runner to consist of galv steel channel with slotted flanges sized to accommodate steel studs (Item 2B). Slotted ceiling runner installed perpendicular to direction of fluted steel deck and secured to valleys with steel masonry anchors spaced max 24 in. (610 mm) OC. When slotted ceiling runner is used, deflection channel (Item 3A) shall not be used. When optional spray-applied fire resistive material is used on the steel deck, slotted ceiling runner secured through spray-applied material to each valley of the steel deck with min 3/16 in. (5 mm) diam steel masonry anchors spaced max 12 in. (305 mm) OC.

METAL-LITE INC — The System

SCAFCO STEEL STUD MANUFACTURING CO

SLIPTRACK SYSTEMS INC — SLP-TRK

A2. Light Gauge Framing* — Clipped Ceiling Runner — As an alternate to the ceiling runner in Items 2A and 2A1, clipped runner to consist of galv steel channel with clips preformed in track flanges which positively engage the inside flange of the steel studs (Item 2B). Track sized to accommodate steel studs (Item 2B). Track flanges to be min 3-1/4 in. (83 mm). Clipped ceiling runner installed perpendicular to direction of fluted steel deck and secured to valleys with steel masonry anchors spaced max 24 in. (610 mm) OC. When clipped ceiling runner is used, deflection

channel (Item 3A) shall not be used. When optional spray-applied fire resistive material is used on deck, clipped ceiling runner secured through spray-applied material to each valley of the steel deck with min 3/16 in. (5 mm) diam steel masonry anchors spaced max 12 in. (305 mm) OC.

TOTAL STEEL SOLUTIONS L L C — Snap Trak

A3. Light Gauge Framing*- Notched Ceiling Runner — As an alternate to the ceiling runners in Items 2A through 2A2, notched ceiling runners to consist of C-shaped galv steel channel with notched return flanges sized to accommodate steel studs (Item 2B). Notched ceiling runner installed perpendicular to direction of fluted steel deck and secured to valleys with steel masonry anchors spaced max 24 in. (610 mm) OC. When notched ceiling runner is used, deflection channel (Item 3A) shall not be used. When optional spray-applied fire resistive material is used on the steel deck, notched ceiling runner secured through spray-applied material to each valley of deck with min 3/16 in. (5 mm) diam steel masonry anchors spaced max 12 in. (305 mm) OC.

DENMAR STEEL INC — Type SCR

B. Studs — Steel studs to be min 3-1/2 in. (89 mm) wide. Studs cut 1/2 to 3/4 in. (13 to 19 mm) less in length than assembly height with bottom nesting in and resting on floor runner and with top nesting in ceiling runner without attachment. When slotted ceiling runner (Item 2A1) is used, steel studs secured to slotted ceiling runner with No. 8 by 1/2 in. (13 mm) long wafer head steel screws at midheight of slot on each side of wall. Stud spacing not to exceed 24 in. (610 mm) OC.

C. Gypsum Board* — Gypsum board sheets installed to a min total thickness of 1-1/4 in. (32 mm) on each side of wall. Wall to be constructed as specified in the individual Wall and Partition Design in the UL Fire Resistance Directory, except that a nom 2 in. (51 mm) gap shall be maintained between the top of the gypsum board and the bottom of the steel floor roof deck and the top row of screws shall be installed into the studs 4-1/2 in. (114 mm) below the lower surface of the floor or roof deck.

3. Joint System — Max separation between bottom of floor or roof and top of wall is 2 in. (51 mm). The joint system is designed to accommodate a max 25 percent compression or extension from its installed width. The joint system consists of an optional deflection channel, forming material and a fill material, as follows:

A. Deflection Channel — (Optional, Not Shown) - A nom 3-5/8 in. (92 mm) wide by 3 in. (76 mm) deep min 24 gauge steel U-shaped channel. Deflection channel installed perpendicular to direction of fluted steel deck and secured to valleys with steel masonry anchors or by welds spaced max 24 in. (610 mm) OC. When optional spray-applied fire resistive material is used on the steel deck, deflection channel secured through spray-applied material to each valley of steel deck with min 1-1/2 in. (38 mm) long by min 3/16 in. (5 mm) diam steel masonry anchors spaced max 12 in. (305 mm) OC. The ceiling runner (Item 2A) is installed within the deflection channel to maintain a 2 in. (51 mm) gap between the top of the ceiling runner and the top of the deflection channel. The ceiling runner is not fastened to the deflection channel.

B. Forming Material* — Min 4 pcf (64 kg/m³) density mineral wool batt insulation cut to the shape of the fluted deck, approximately 20 percent larger than the area of the flutes, with a length equal to the overall thickness of the wall. Insulation compressed into flutes of the steel floor or roof deck above the top of the deflection channel or ceiling runner with the ends flush with the surfaces of the wall. Additional 1-1/4 in. (32 mm) wide sections of mineral wool batt insulation are compressed 50 percent in thickness and installed cut edge first to completely fill the gap above the top of the gypsum board. The forming material shall be installed flush with both surfaces of wall.

FIBREX INSULATIONS INC — FBX Safing Insulation

IIG MINWOOL L L C — MinWool-1200 Safing

ROCK WOOL MANUFACTURING CO — Delta Board or Delta-8

ROXUL INC — Type Safe

THERMAFIBER INC — Type SAF

C. **Fill, Void or Cavity Material*** — Min 1/16 in. (1.6 mm) dry thickness (1/8 in. or 3.2 mm wet thickness) of fill material sprayed or brushed on each side of the wall in the flutes of the steel floor or roof deck and between the top of the gypsum board and the bottom of the steel floor or roof deck to completely cover mineral wool and overlap a min of 1/2 in. (13 mm) onto gypsum board and steel deck on both sides of wall. When the steel deck is coated with spray applied material, the fill material shall overlap min 2 in. (51 mm) onto the spray applied material.

3M COMPANY — FireDam™ Spray 200

D. **Isolation Pad** — (Optional, Not Shown) - As an option, max 1/2 in. (13 mm) thick molded high density glass fiber isolation pads may be installed between the deflection channel (Item 3A) and the steel floor or roof deck for sound control purposes. The isolation pad shall be cut to the width of the deflection channel and shall be installed along the entire length of the wall. When the isolation pad is used, the deflection channel shall be secured to the steel deck, through the isolation pad, with mechanical fasteners in conjunction with steel fender washers and neoprene isolation grommets supplied by the maker of the isolation pad material.

*Bearing the UL Classification Mark

Last Updated on 2006-03-31

[Questions?](#)

[Notice of Disclaimer](#)

[Page Top](#)

[Copyright © 2006 Underwriters Laboratories Inc.®](#)

The appearance of a company's name or product in this database does not in itself assure that products so identified have been manufactured under UL's Follow-Up Service. Only those products bearing the UL Mark should be considered to be Listed and covered under UL's Follow-Up Service. Always look for the Mark on the product.

UL permits the reproduction of the material contained in the Online Certification Directory subject to the following conditions: 1. The Guide Information, Designs and/or Listings (files) must be presented in their entirety and in a non-misleading manner, without any manipulation of the data (or drawings). 2. The statement "Reprinted from the Online Certifications Directory with permission from Underwriters Laboratories Inc." must appear adjacent to the extracted material. In addition, the reprinted material must include a copyright notice in the following format: "Copyright © 2006 Underwriters Laboratories Inc.®"

An independent organization working for a safer world with integrity, precision and knowledge.

