

KINETICS™

Isolation Hangers Model AF



Description

Model AF fiberglass hangers are specifically designed as a noise stop isolator for use in wire-supported, suspended ceiling systems. These hangers are a combination of uniquely permanent, inorganic Kinetics fiberglass and a zinc-plated metal assembly. This creates a combination that is essentially non-corrosive in all typical building environments. The incorporation of galvanized No. 12 gauge wire adapts the Model AF hanger directly into the standard tie wire system used by ceiling installation trades.

Model AF hangers are available in two (2) load ranges:

- Model AF-100 load range, 20-100 pounds (9-46 kg), used for lightweight acoustical tile ceilings.
- Model AF-200 load range, 50-200 pounds (23-91 kg), used for heavy gypsum board and plaster ceilings.

Both Model AF hangers will carry a 500% overload without failure.

Features

- Permanently resilient fiberglass isolator pad
- Constant natural frequency in wide load range
- Load capacities 20 lbs. to 200 lbs. (9 kg to 91 kg)
- 500% overload fail-safe assembly

Application

Kinetics Model AF hangers are recommended for use in acoustically isolated ceiling systems.

Acoustical tile ceilings can be supported by Model AF-100 hangers to stop high frequency “buzzing” of the ceiling grid work, caused by equipment such as transformers, chillers, and other mechanical equipment sources in the audible frequency range.

Heavy ceilings of gypsum board and plaster can be supported by Model AF hangers to increase the sound transmission loss.

Standard Model AF hangers are shipped fully assembled and ready for use.

Hanger Type	Standard Ratings				Dimensions									
	Capacity		Deflection		L		W		A		B		D	
	lbs	kg	in	mm	in	mm	in	mm	in	mm	in	mm	in	mm
AF-50	50	23	0.36	9	4.75	121	2.19	56	0.50	13	0.88	22	0.27	7
AF-100	100	45	0.28	7	4.75	121	2.19	56	0.50	13	0.88	22	0.27	7
AF-200	200	91	0.19	5	4.75	121	2.19	56	0.50	13	0.88	22	0.27	7

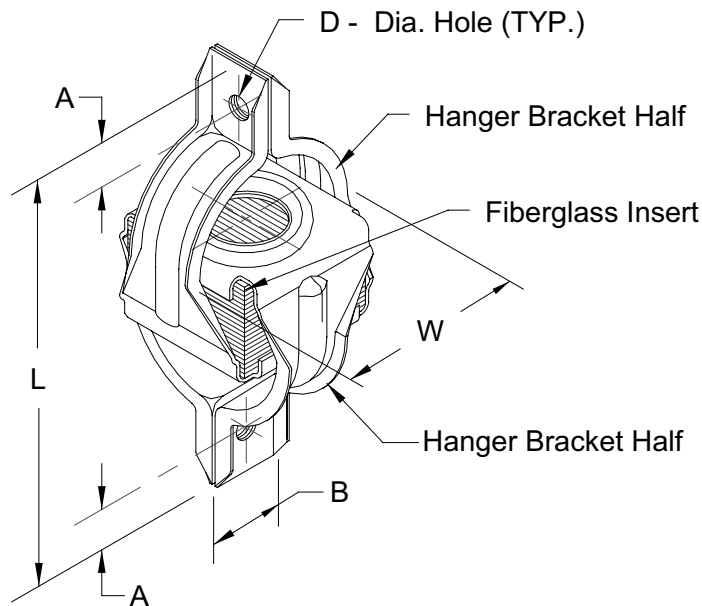

Specifications

Hangers shall consist of a fiberglass isolator encased in an antishort-circuit reinforced steel bracket which will accommodate up to #8 suspension wire or a 1/4" (6.35 mm) bolt or screw.

The fiberglass isolator shall be 1" (25 mm) thick, precompressed, molded fiberglass composed of glass fibers produced by a multiple flame attenuation process which generates nominal fiber diameters not to exceed 0.00022" (5.6 microns) and shall have been stabilized by precompression ten (10) times to three (3) times the maximum rated load of the material used.

The hanger assembly shall be zinc-plated reinforced steel and shall carry a five (5) times maximum rated load overload without failure. Hangers shall be Model AF as manufactured by Kinetics Noise Control, Inc.



United States

6300 Irelan Place
P.O. Box 655
Dublin, Ohio 43017
Phone: 614-889-0480
Fax: 614-889-0540

Canada

3570 Nashua Drive
Mississauga, Ontario
L4V 1L2
Phone: 905-670-4922
Fax: 905-670-1698

www.kineticsnoise.com
sales@kineticsnoise.com

Kinetics Noise Control, Inc. is continually upgrading the quality of our products. We reserve the right to make changes to this and all products without notice.