

Kinetics IsoMax

Affordable Noise Control

Model IsoMax sound isolation clips from Kinetics Noise Control offer designers a highly effective, low cost product for creating noise control walls. A recent scientific study¹ shows acoustical de-coupling using Model IsoMax can even enhance the performance of engineered damped drywall (EDD).²

During the study, a number of configurations were tested. Three (3) of these configurations are illustrated at right with estimated installed cost³.

STC 61 - \$6.71/sq ft

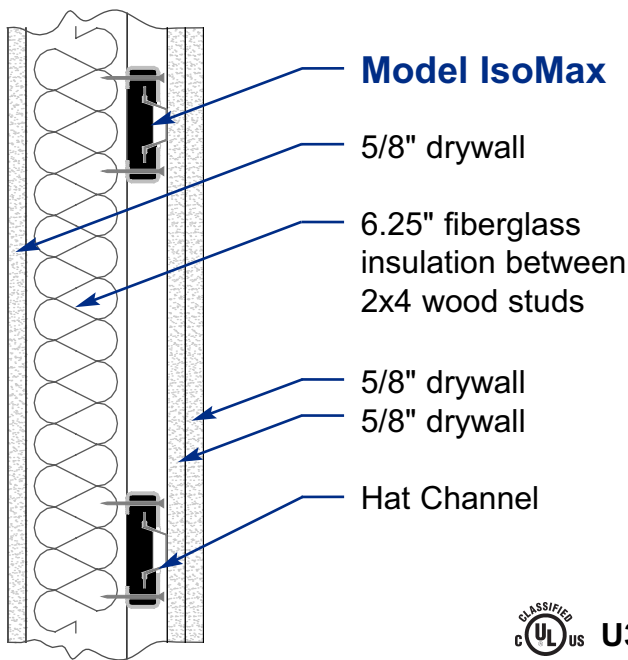

CLASSIFIED
 **U305**
 (see complete marking on product)

Lab performance: **Model IsoMax** with standard drywall
 STC - Sound Transmission Class per ASTM E 90

ASTC 36 - \$3.58/sq ft

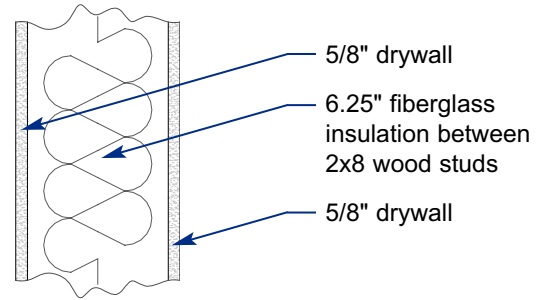

ASTC 44 - \$11.71/sq ft

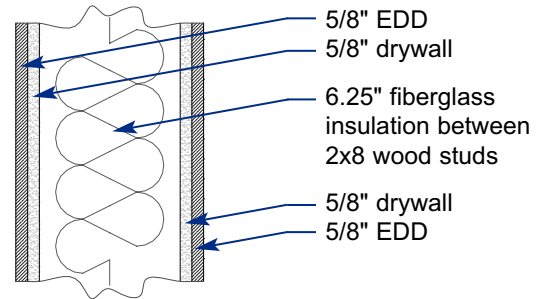

ASTC 58 - \$9.73/sq ft

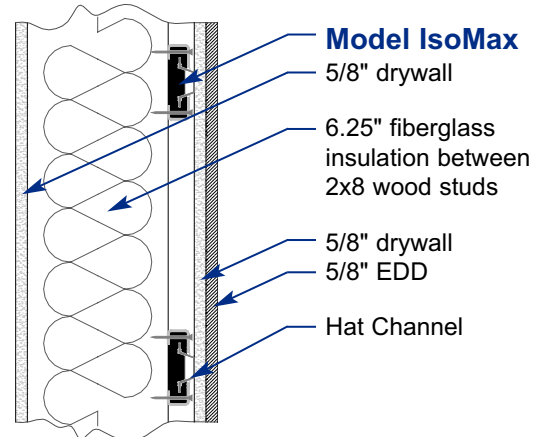

ASTC - Apparent Sound Transmission Class
 per ASTM E 336

¹ Lilkendey, R. & Siebein, G. "Case studies illustrating the importance of de-coupling the mass layers of demising walls in multifamily luxury condominiums and townhomes", *Proceedings of Noise-Con, 116(1)*, 454-465, Institute of Noise Control Engineering of the USA, (2007).

² The Engineered Damped Drywall (EDD) used in the study was QuietRock QR-530. Other types should be evaluated separately for cost and performance.

³ Cost estimates for each assembly were prepared using data from 2007 RS Means cost data along with current market rates for specialty materials. Cost estimates were not part of the cited scientific study.