

## Kinetics KSBC Seismically Rated Beam Clamp

There is frequently a desire to attach seismic restraints to roof or floor support I-beams. Equally often the ability to add holes to these beams for bolts or to weld tabs to them is not possible or practical. In these conditions, Beam Clamps can often be used as long as they are of the proper type, are properly sized and are properly installed.

Before proceeding in the selection of a beam clamp, first determine that the beams to which the restraint is to be attached are oriented properly. All connections must be positive and not rely on friction to carry the seismic load. This means that the direction of the cable and/or strut used to resist the forces must be at right angles to the beam. If the cable or strut is oriented in line with the beam axis, a beam clamp cannot be used and a weld-on tab or bolted connection is required.

If, based on the above, it is possible to use a beam clamp, an appropriate type and size must be selected. Most commercially available Beam Clamps are not appropriate for the attachment of restraints as they are designed to support vertical loads and not transfer horizontal ones. Unless rated for horizontal loads by the manufacturer, "conventional" beam clamps should not be used. As a minimum, appropriate beam clamps must meet the following set of requirements:

- 1) Beam clamps must engage both sides of a beam such that, even if the attachment bolt is not fully tightened, there is **no** possibility that the clamp can be pulled off of the beam.
- 2) Both the clamp bracket itself and the arm that engages the opposite side of the beam must be adequate to transfer the full horizontal load that is required for the application
- 3) The hardware used to attach the restraint or strut bracket to the beam clamp must also be adequate to transfer the full horizontal load that is required for the application.
- 4) All components used must be rated using factors consistent with code requirements and appropriate for seismic design.

The Kinetics Noise Control KSBC Beam Clamp is designed to address the horizontal loads expected from seismic events. The two (2) sizes available use 3/8" and 1/2" attachment hardware and are equivalent to full bolted connections for hardware of the same size. (Thus if documentation requires that a 3/8" bolt be used, a 3/8" beam clamp is equally acceptable.)

Note that, as with any seismic connection to structural elements, the ability of the structural element to resist the design seismic load is known only by the structural engineer of record. As these forces can be significant and because beams used to support structures are typically designed around the vertical or gravity loads, there may be structural issues that must be addressed when connecting to and applying large horizontal forces to these members. Always, before connecting restraints to beams or

### KSBC Beam Clamp

PAGE 1 OF 4

RELEASE DATE: 1/6/05



DUBLIN, OHIO, USA • MISSISSAUGA, ONTARIO, CANADA

Toll Free (USA only): 800-959-1229  
International: 614-889-0480  
Fax: 614-889-0540  
World Wide Web: [www.kineticsnoise.com](http://www.kineticsnoise.com)  
Email: [sales@kineticsnoise.com](mailto:sales@kineticsnoise.com)

DOCUMENT:

P8.2.7



other structural elements, ensure that the capacity of the elements to resist these loads is adequate. Kinetics Noise Control is not in a position to accept any responsibility for problems that develop from restraints being attached to inadequate structural elements.

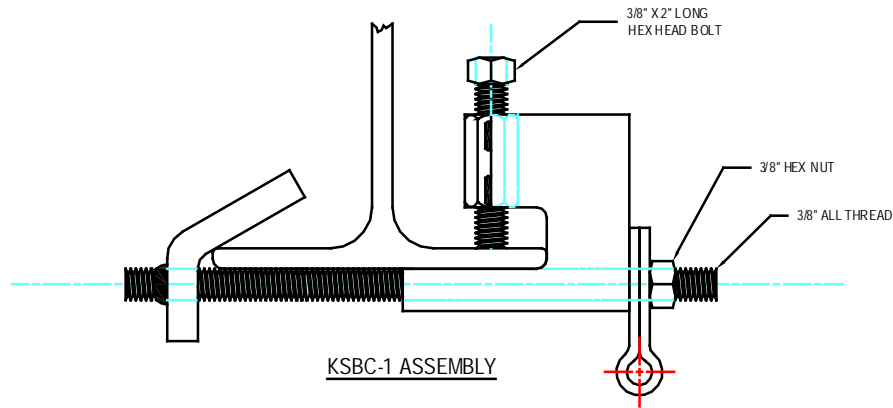

Typical KSBC shown with KSUA attachment clip  
(Can also be used with KSCA clip)

## KSBC Beam Clamp

PAGE 2 OF 4

RELEASE DATE: 1/6/05



DUBLIN, OHIO, USA • MISSISSAUGA, ONTARIO, CANADA

Toll Free (USA only): 800-959-1229  
International: 614-889-0480  
Fax: 614-889-0540  
World Wide Web: [www.kineticsnoise.com](http://www.kineticsnoise.com)  
Email: [sales@kineticsnoise.com](mailto:sales@kineticsnoise.com)

DOCUMENT:

P8.2.7



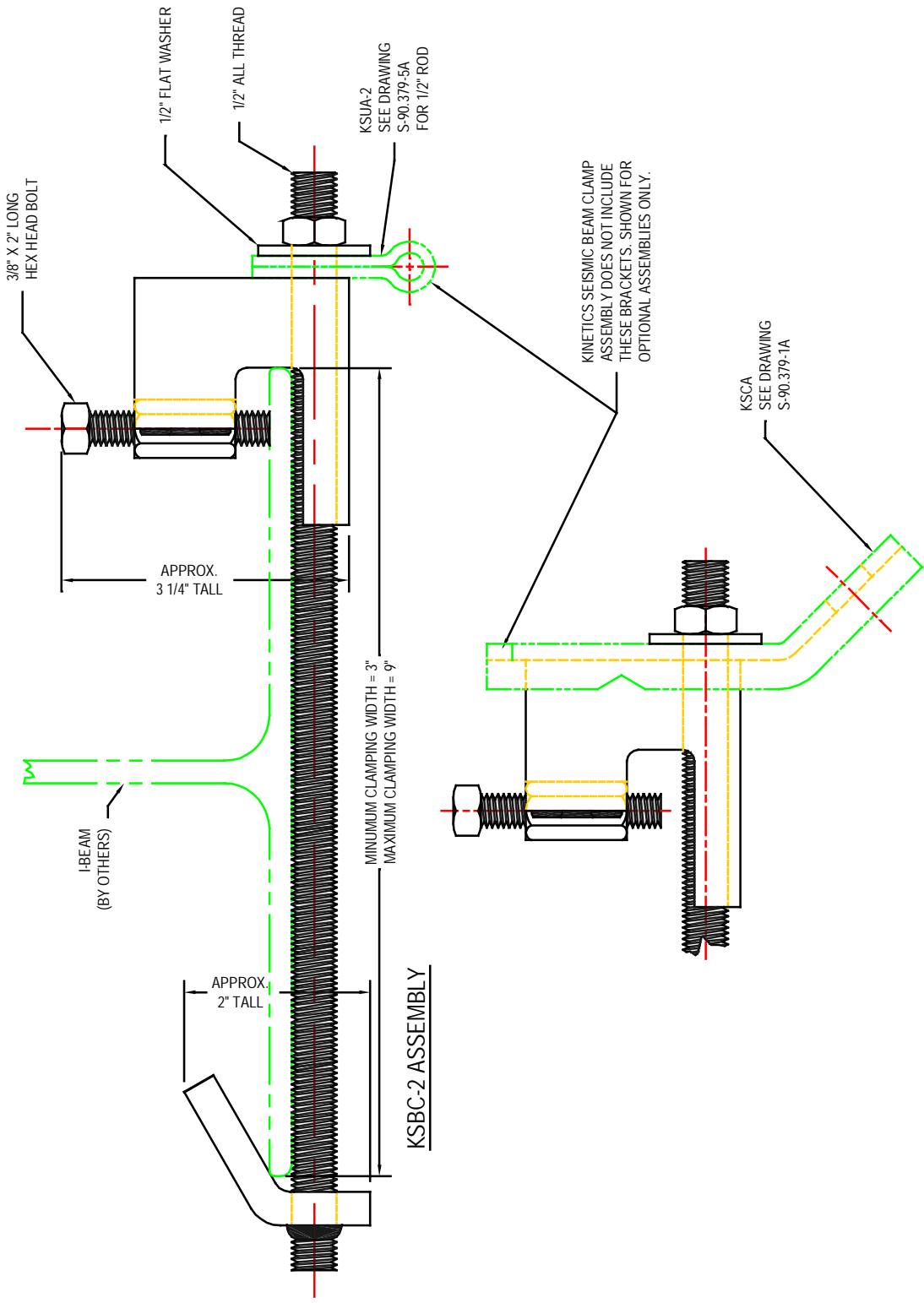

# KSBC Beam Clamp

PAGE 3 OF 4

RELEASE DATE: 1/6/05



DUBLIN, OHIO, USA • MISSISSAUGA, ONTARIO, CANADA

Toll Free (USA only): 800-959-1229  
 International: 614-889-0480  
 Fax: 614-889-0540  
 World Wide Web: [www.kineticsnoise.com](http://www.kineticsnoise.com)  
 Email: [sales@kineticsnoise.com](mailto:sales@kineticsnoise.com)

DOCUMENT:  
**P8.2.7**



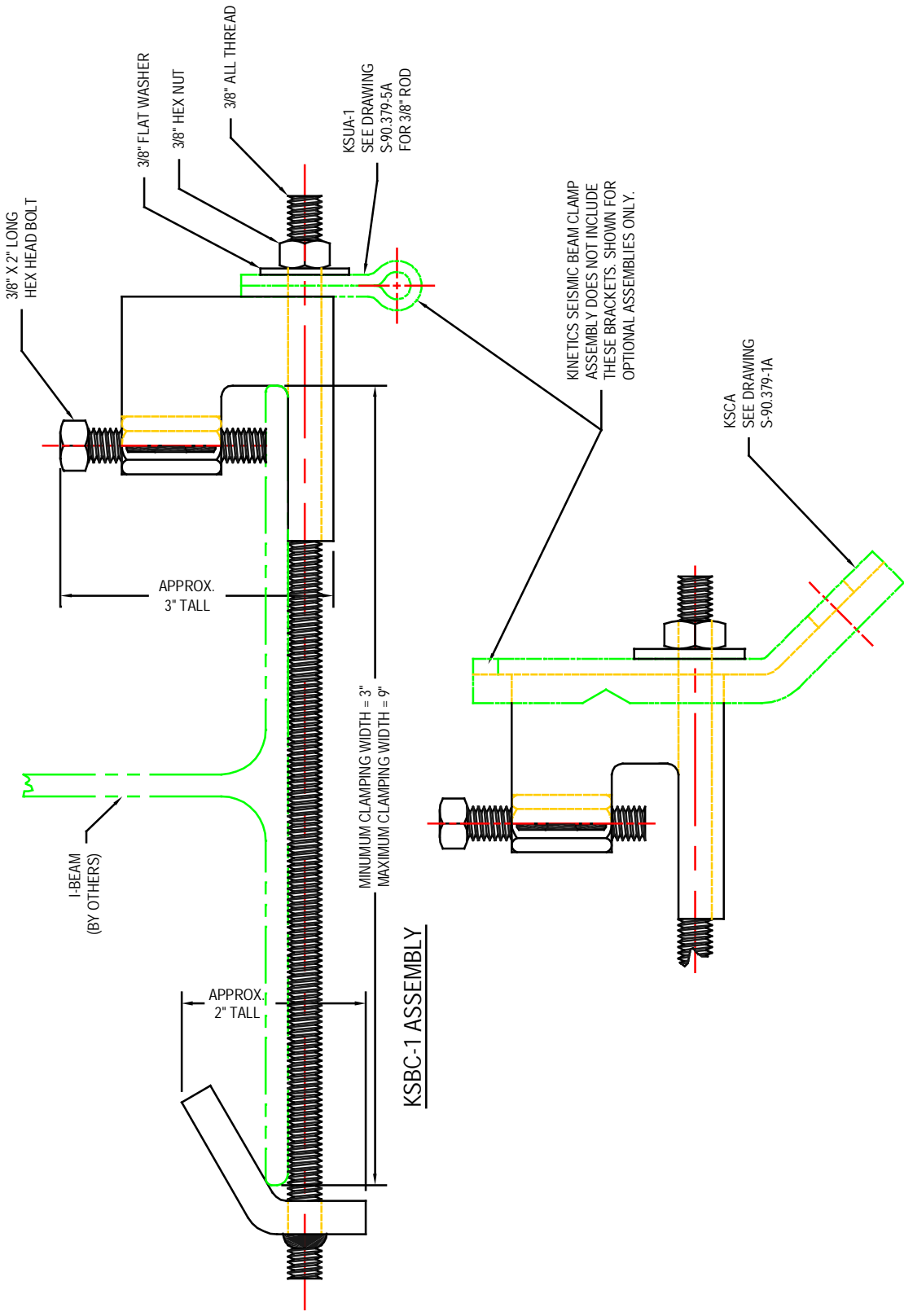

### KSBC Beam Clamp

PAGE 4 OF 4

RELEASE DATE: 1/6/05



DUBLIN, OHIO, USA • MISSISSAUGA, ONTARIO, CANADA

Toll Free (USA only): 800-959-1229  
 International: 614-889-0480  
 Fax: 614-889-0540  
 World Wide Web: [www.kineticsnoise.com](http://www.kineticsnoise.com)  
 Email: [sales@kineticsnoise.com](mailto:sales@kineticsnoise.com)

DOCUMENT:  
**P8.2.7**

