

# Requirements for Ductwork Restraints

## Definitions and Locating Requirements

SMACNA has developed a set of restraint placement criteria based on analytical review, practical experience, and historical analysis. The criteria presented in this manual is generally based on the SMACNA criteria, with the only exceptions being an extrapolation of the data to higher seismic force levels and an increase in allowable spacing where restraint hardware capacity (as illustrated in the SMACNA guide) would be exceeded.

With respect to the conceptual restraint arrangement illustrations, the SMACNA concepts are appropriate and are referenced here.

In general, ductwork is restrained in lengths called "runs." Therefore before getting into a detailed review of the restraint systems it is imperative that a definition of "run" as well as other key terms be addressed.

### Definitions

**Axial** In the direction of the axis of the duct.

**Lateral** Side to side when looking along the axis of the duct.

**Restraint** Any device that limits the motion of a duct in either the lateral or axial direction.

**Run** A more or less straight length of duct where offsets are limited to not more than  $S/16$  where  $S$  is the maximum permitted lateral restraint spacing (a function of ductwork size and seismic forces) and the total length is greater than  $S/2$ . (Note:  $S$  dimensions for various conditions are listed in Chapter D4.)

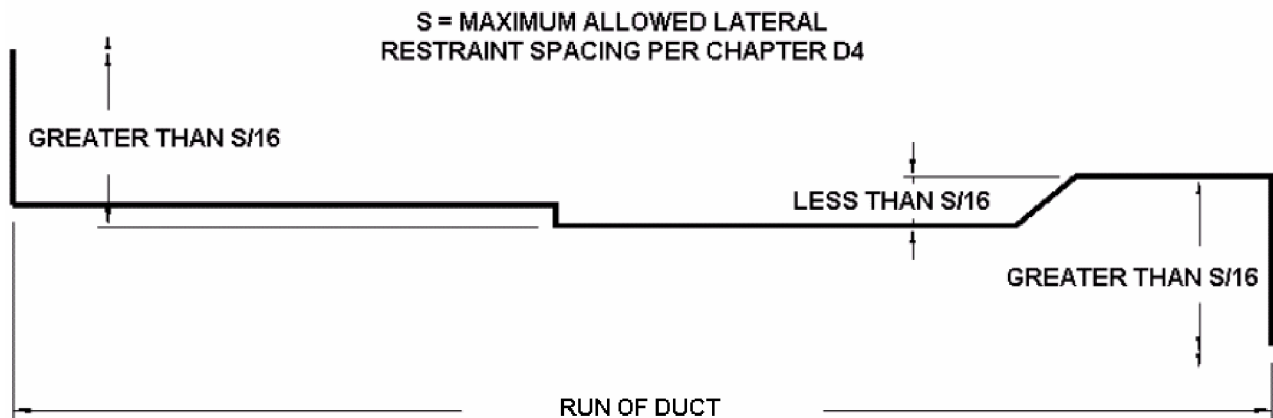

**Short Run** A run as defined above where the total length is less than  $S/2$  and where it is connected on both ends to other runs or short runs.

## DEFINITIONS AND LOCATING REQUIREMENTS

PAGE 1 OF 6

RELEASE DATE: 11/6/07



DUBLIN, OHIO, USA • MISSISSAUGA, ONTARIO, CANADA

Toll Free (USA only): 800-959-1229  
International: 614-889-0480  
Fax: 614-889-0540  
World Wide Web: [www.kineticsnoise.com](http://www.kineticsnoise.com)  
Email: [sales@kineticsnoise.com](mailto:sales@kineticsnoise.com)

DOCUMENT:

**D8.4.1**



**Drop** A length of duct that normally extends down from an overhead run and connects to a piece of equipment, usually through some type of flex connector. The drop can also extend horizontally. In order to qualify as a drop, the length of this pipe must be less than  $S/2$ . If over  $S/2$ , the length of pipe would be classified as a run.

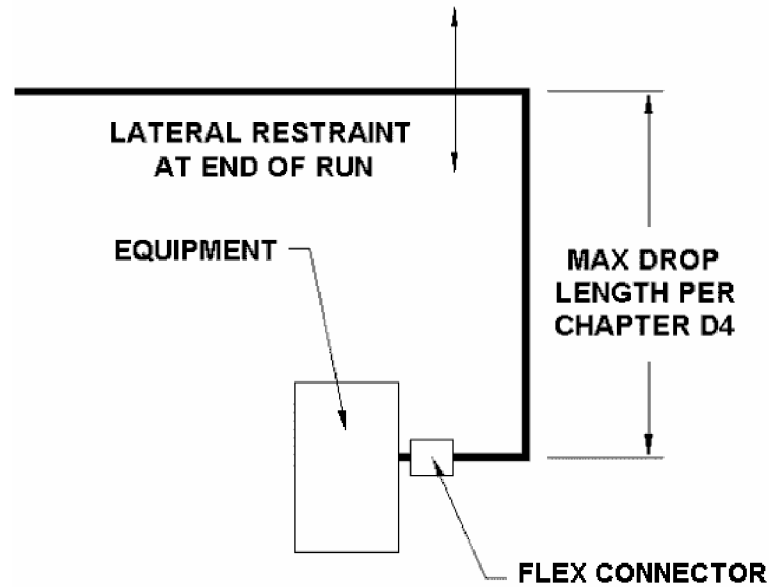

### Restraint Requirements

- 1) Full runs (greater in length than  $S/2$ ) must be restrained in both the axial and lateral direction. If the run is not a short run or a drop, it must, as a minimum, be laterally restrained at the last support location on each end.

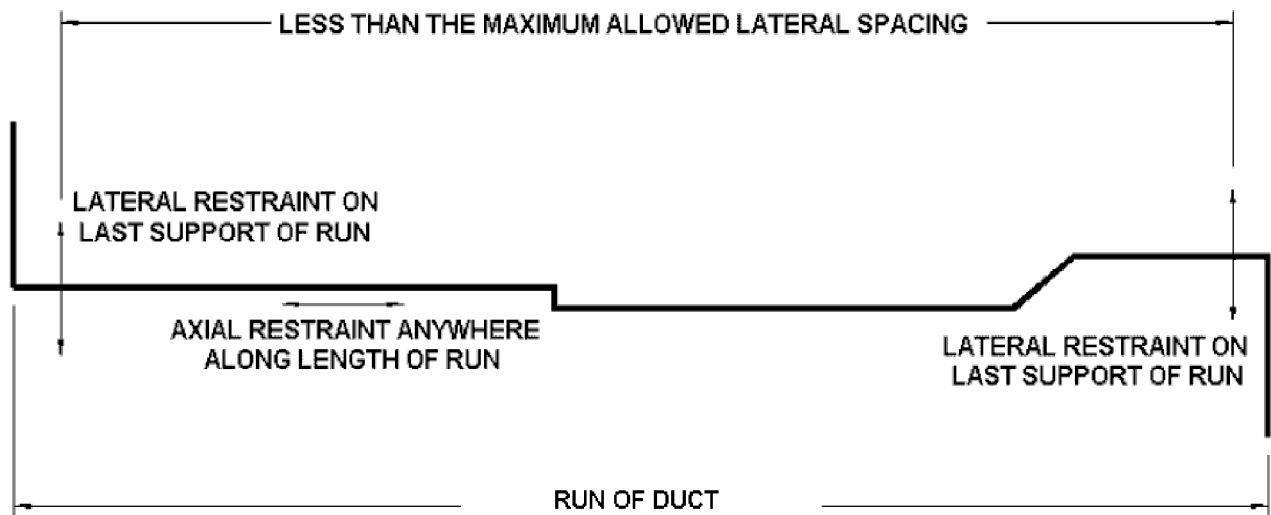

## DEFINITIONS AND LOCATING REQUIREMENTS



DUBLIN, OHIO, USA • MISSISSAUGA, ONTARIO, CANADA

Toll Free (USA only): 800-959-1229  
 International: 614-889-0480  
 Fax: 614-889-0540  
 World Wide Web: [www.kineticsnoise.com](http://www.kineticsnoise.com)  
 Email: [sales@kineticsnoise.com](mailto:sales@kineticsnoise.com)

DOCUMENT:  
**D8.4.1**



- 2) If a run is longer than “S,” intermediate restraints are required to limit the spacing to that permitted by the building code (see table in Chapter D4).

**MULTIPLE RESTRAINTS ON LONG RUNS**

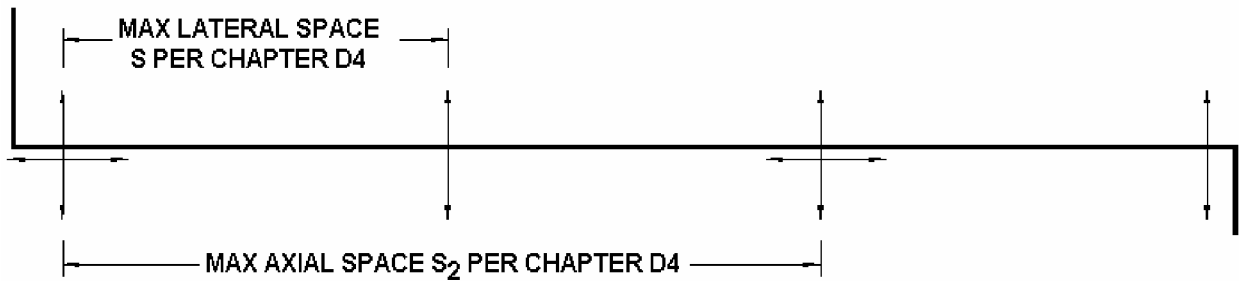

- 3) Axial restraints attached to the run of duct along its length must be connected using a positive connection between the duct and the restraint.
- 4) Short runs or drops need only have one lateral and one axial restraint.

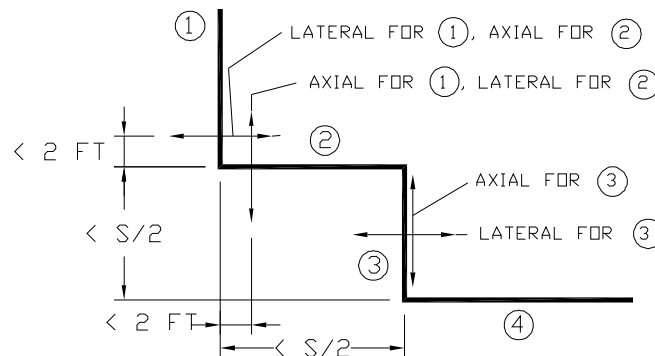

- 5) If a lateral restraint is located within 2 feet of a corner (based on a measurement to the duct centerline) or is immediately adjacent to the duct for larger ducts, it can be used as an axial restraint on the intersecting run.

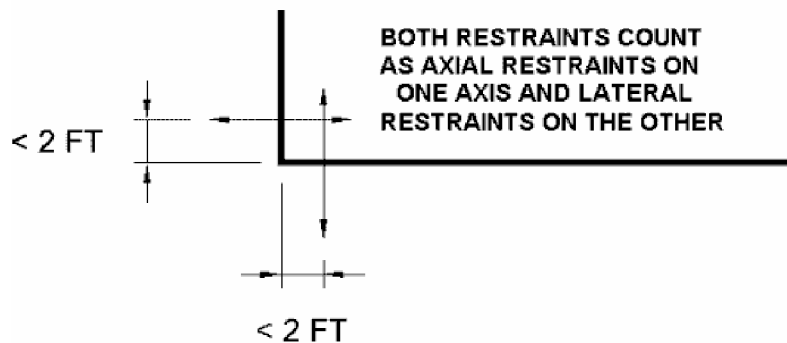

- 6) Larger ducts cannot be restrained with restraints located on smaller branches.

**DEFINITIONS AND LOCATING REQUIREMENTS**



Toll Free (USA only): 800-959-1229  
 International: 614-889-0480  
 Fax: 614-889-0540  
 World Wide Web: www.kineticsnoise.com  
 Email: sales@kineticsnoise.com



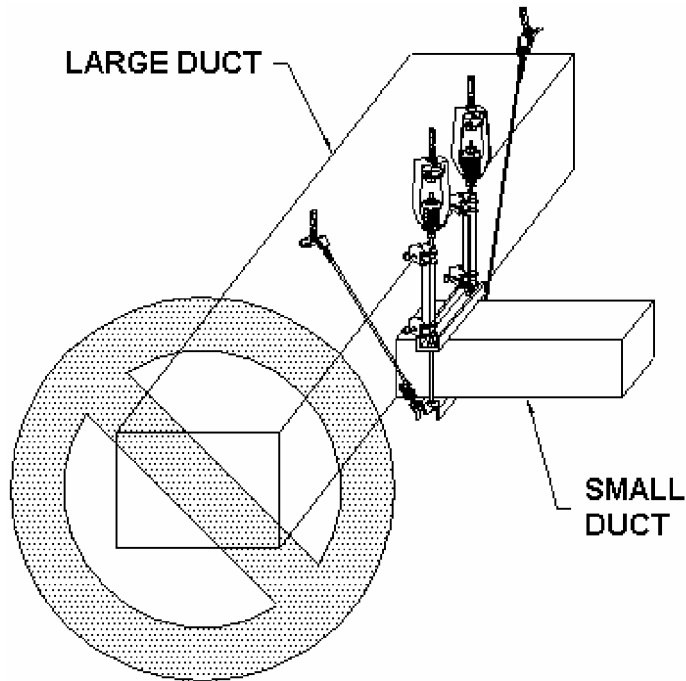

7) Within a run, the type of restraint used must be consistent. For example, mixing a strut with cable restraints is not permitted.

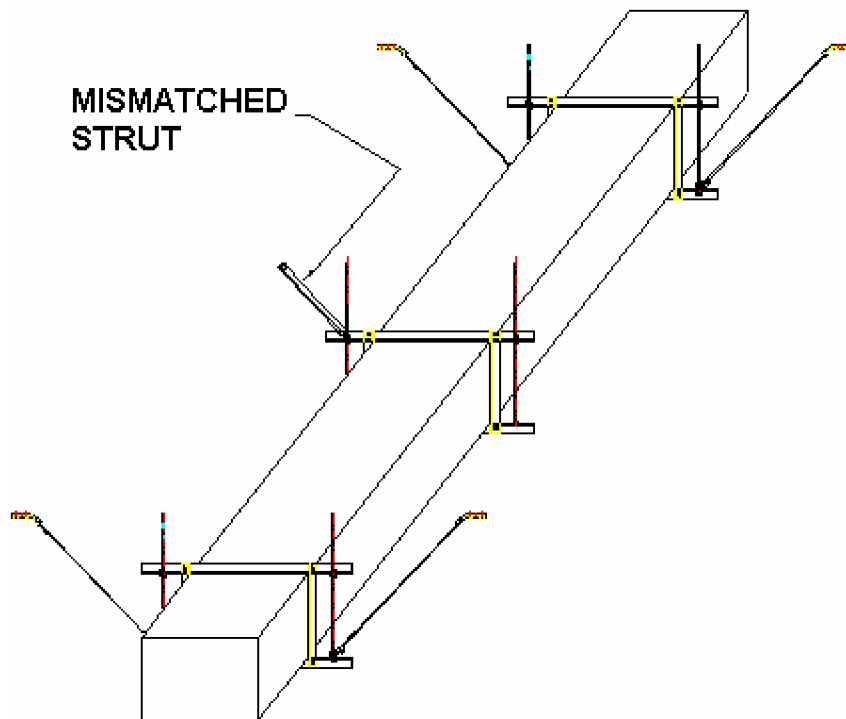

8) With longer hanger rods, rod stiffeners are likely to be required. Refer to the

## DEFINITIONS AND LOCATING REQUIREMENTS

PAGE 4 OF 6

RELEASE DATE: 11/6/07



Toll Free (USA only): 800-959-1229  
 International: 614-889-0480  
 Fax: 614-889-0540  
 World Wide Web: [www.kineticsnoise.com](http://www.kineticsnoise.com)  
 Email: [sales@kineticsnoise.com](mailto:sales@kineticsnoise.com)



appropriate table in Chapter D4 to determine: (1) if needed, (2) what size stiffener material is appropriate, and (3) how frequently it needs to be clamped to the hanger rod.

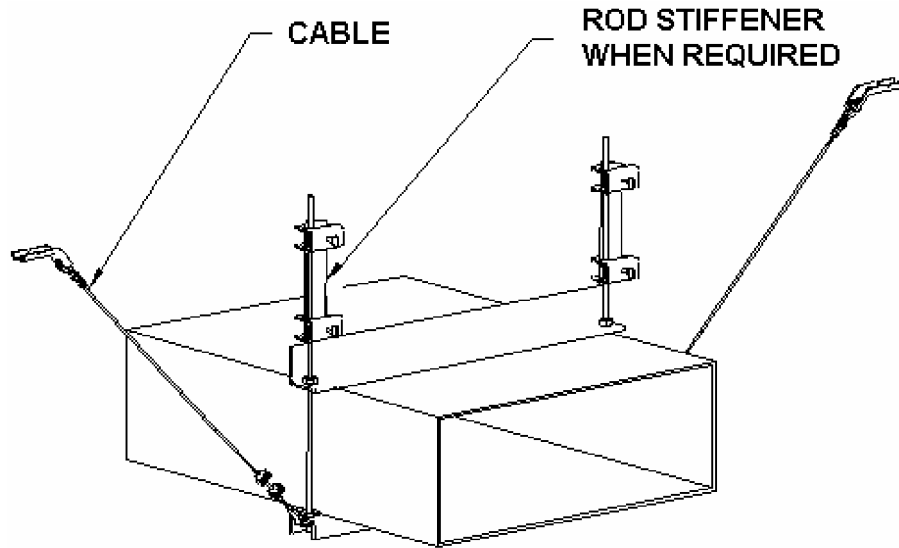

- 9) In addition to possibly requiring rod stiffeners, when struts are used to restrain ductwork, the size of the hanger rod and its anchorage also become critical. Again refer to the appropriate table in Chapter D4 to determine the minimum allowable size for the hanger rod and anchor.

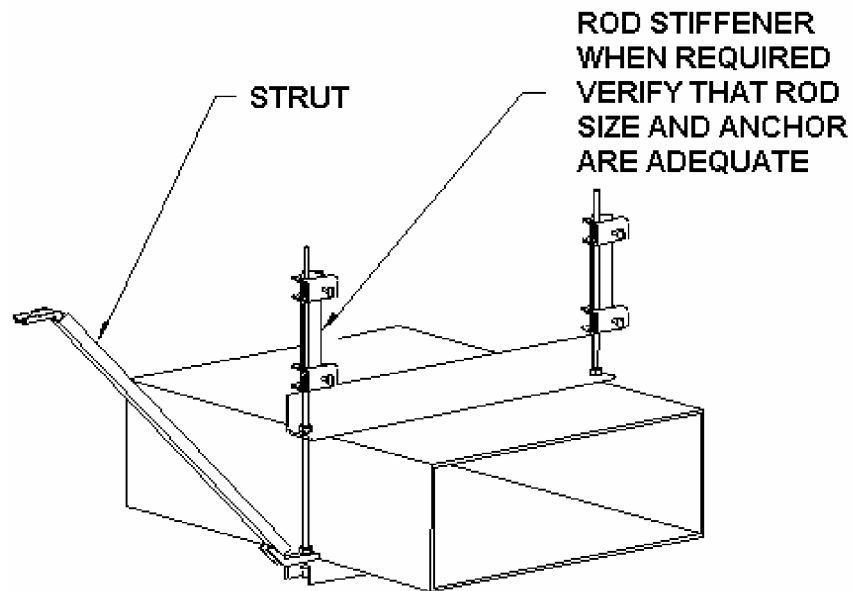

- 10) In some cases, it may be possible to locate the ducts close enough to the support

## DEFINITIONS AND LOCATING REQUIREMENTS

structure (12") to eliminate the need for restraint. (Refer to the building code review chapter (D2) to determine if this exemption is applicable.) If it is applicable, the 12" dimension is measured as shown below.

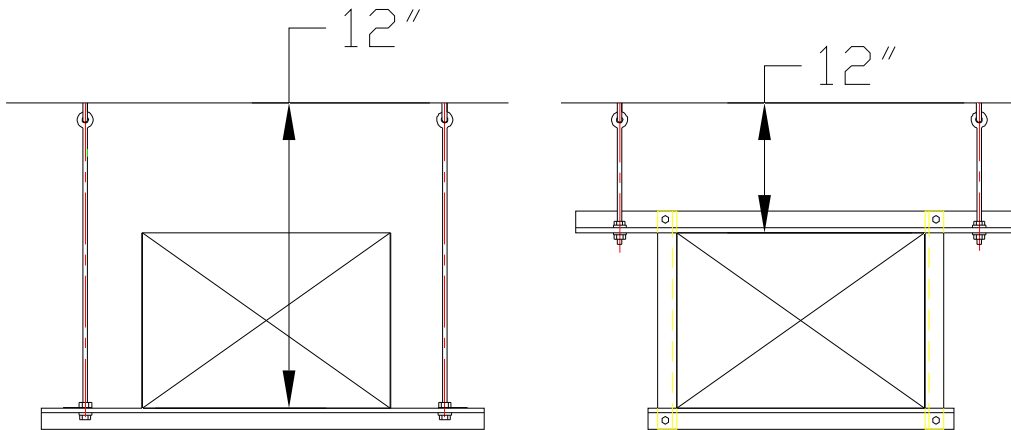

- 11) When using the above rule it is critical that all support locations in a run conform. If even one location exceeds 12", the run cannot be exempted from restraint.

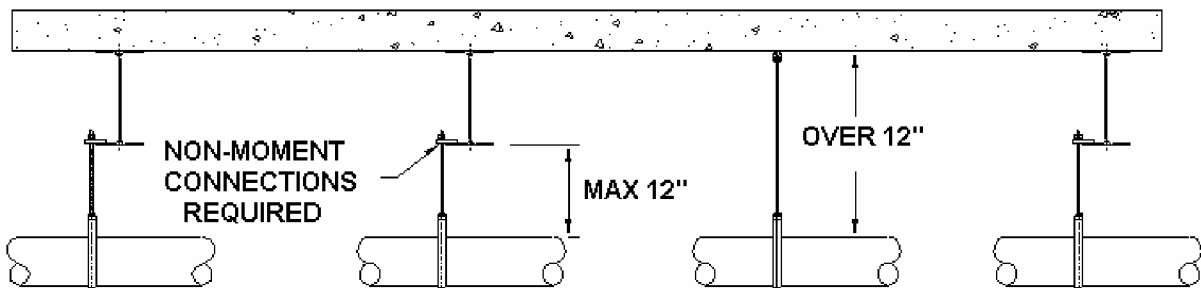

## DEFINITIONS AND LOCATING REQUIREMENTS

PAGE 6 OF 6

RELEASE DATE: 11/6/07



DUBLIN, OHIO, USA • MISSISSAUGA, ONTARIO, CANADA

Toll Free (USA only): 800-959-1229  
 International: 614-889-0480  
 Fax: 614-889-0540  
 World Wide Web: [www.kineticsnoise.com](http://www.kineticsnoise.com)  
 Email: [sales@kineticsnoise.com](mailto:sales@kineticsnoise.com)

DOCUMENT:

D8.4.1

