

Floor- or Roof-Supported Pipe Restraint Arrangements

Although the basic principle of diagonal bracing is almost always used to design restraint systems, the actual arrangements of these systems can vary significantly. Despite what looks like substantially different designs, the design forces in the members remain the same, and the same rules apply when sizing components. Illustrated here are many different floor- and roof-mounted restraint arrangements, all of which can be used in conjunction with the design “rules” provided in this manual.

Details of the end connections and anchorage hardware are shown in subsequent sections of this manual. It is assumed in this manual that the restraint component is attached to a structural element capable of resisting the design seismic load.

This manual addresses diagonal bracing oriented between horizontal and 60 degrees from the horizontal. Angles in excess of 60 degrees to the horizontal are not permitted.

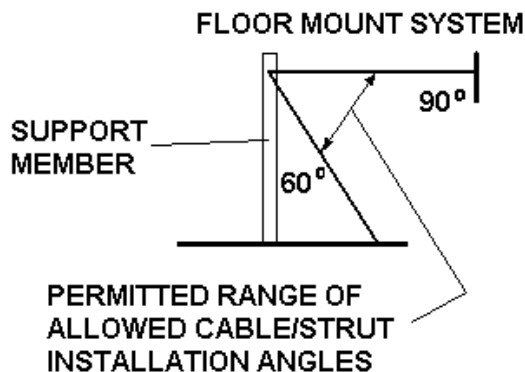

When installing restraints, lateral restraints should be installed perpendicular (± 10 degrees) to the pipe in the plan view. Axial restraints should be in line with the pipe (± 10 degrees) again in the plan view. All restraint cables should be aligned with each other. See the sketch below.

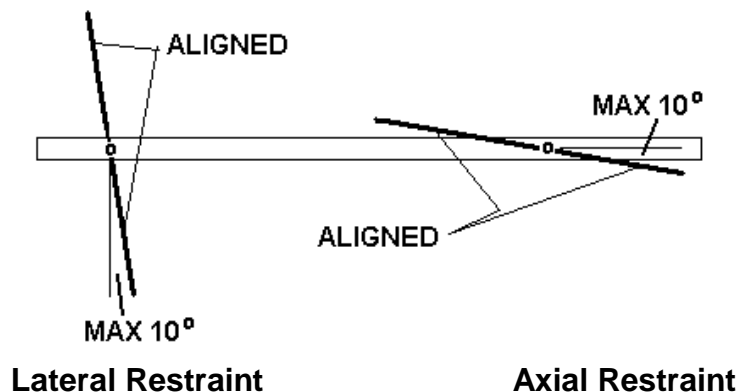

FLOOR- OR ROOF-SUPPORTED PIPE RESTRAINT ARRANGEMENTS

PAGE 1 OF 6

RELEASE DATE: 1/6/04



Toll Free (USA only): 800-959-1229
International: 614-889-0480
Fax: 614-889-0540
World Wide Web: www.kineticsnoise.com
Email: sales@kineticsnoise.com

DOCUMENT:

D7.4.3



In general, when restraining piping the component actually being restrained is the support device for the pipe. For floor-mounted equipment this would normally be either a fabricated frame or a trapeze bar. Because the goal is to restrain the actual pipe, it is necessary that the restrained element be connected to the pipe in such a way as to transfer the appropriate forces between the two. For example, if an axial restraint is installed on a trapeze bar which in turn supports a pipe that is carried by a roller, it is obvious that the axial forces generated by the pipe cannot be restrained by the connection to the trapeze bar and some other arrangement is needed.

With respect to firmly connecting restraints to piping, there are a few general rules that should be followed:

- 1) A pipe carried on a roller cannot be restrained in the axial direction by restraining the support.
- 2) If the pipe is wrapped with insulation and an axial restraint is needed, a riser clamp should be tightly clamped to the pipe prior to wrapping it with insulation and the restraint device should penetrate the insulation material.
- 3) If the pipe is wrapped with insulation and lateral restraint is needed, a hardened insulation material should be fitted at the restraint location.
- 4) Piping which expands and contracts significantly should include expansion joints or loops between each axially restrained component.
- 5) Trapeze-mounted piping should be tightly clamped to the trapeze bar.

In addition, when sizing restraint components for multiple pipes the total weight of all of the restrained piping must be considered.

Floor- or Roof-mounted Systems Restrained with Cables

Floor- or roof-mounted systems may include supports for single pipes or multiple pipes. Typically, simple box frames are fabricated to support piping, whether it is a single pipe or multiple pipes.

Lateral Restraint Examples

For a cable-restrained pipe support bracket there are four options normally encountered for non-isolated systems and four similar arrangements for isolated systems. These options are shown below. The vertical legs of the support bracket must be sized to carry both the weight load of the supported pipes as well as the vertical component of the seismic forces. Refer to Chapter D4 for more detailed information as to how to size these members.

FLOOR- OR ROOF-SUPPORTED PIPE RESTRAINT ARRANGEMENTS

PAGE 2 OF 6

RELEASE DATE: 1/6/04



Toll Free (USA only): 800-959-1229
International: 614-889-0480
Fax: 614-889-0540
World Wide Web: www.kineticsnoise.com
Email: sales@kineticsnoise.com

DOCUMENT:

D7.4.3



OUTSIDE RESTRAINT

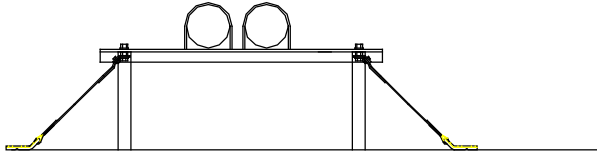

SINGLE LEG RESTRAINT

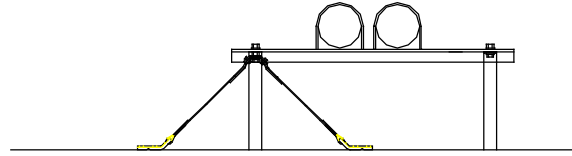

X BRACED

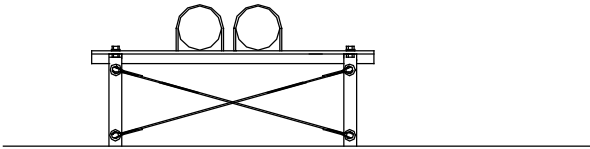

INSIDE RESTRAINT

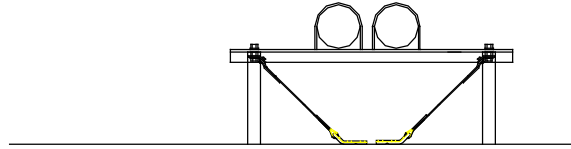

Lateral Cable Restraints used in conjunction with floor-mounted pipe support stands (Non-isolated)

OUTSIDE RESTRAINT

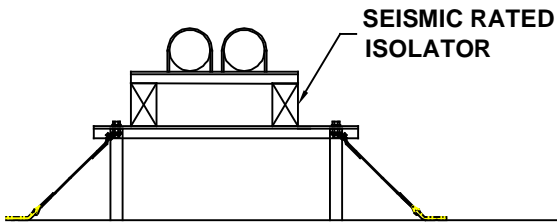

SINGLE LEG RESTRAINT

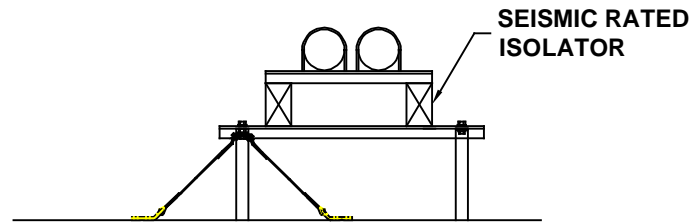

X BRACED

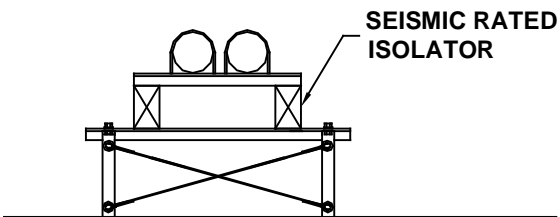

INSIDE RESTRAINT

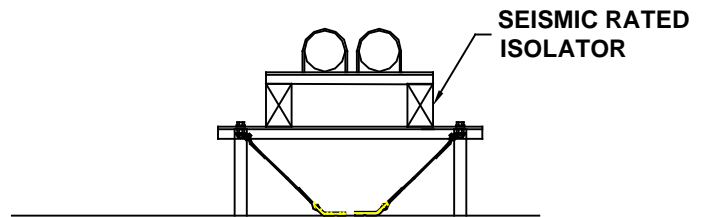

Lateral Cable Restraints used in conjunction with floor-mounted pipe support stands (Isolated)

FLOOR- OR ROOF-SUPPORTED PIPE RESTRAINT ARRANGEMENTS

Axial Restraint Examples

When axially restraining piping, a trapeze or riser clamp tightly clamped to the pipe is the most common connecting device used, although a weld-on tab or connection to a flange is a possibility in some cases. Details on these connections will be addressed in later sections.

If the details of the connection are ignored at this point, general axial restraint arrangements recognized in this manual are illustrated below.

Note: Axial restraints offset from the restrained pipe will generate additional bending forces in the restrained pipe. This is true whether mounted to one end of a trapeze or along side a single pipe rather than directly under its center. When the restraint is offset, the maximum permissible offset from the center of the pipe is 1 pipe diameter. For trapezoided systems supporting multiple pipes, a single axial restraint should be located at the approximate center of the trapeze bar or pairs of axial restraints should be installed on each end of the trapeze bar or support frame.

RESTRAINED PIPE

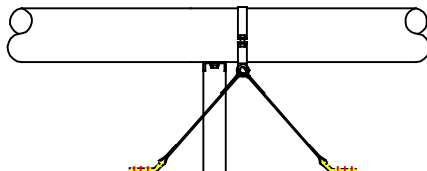

RESTRAINED SUPPORT

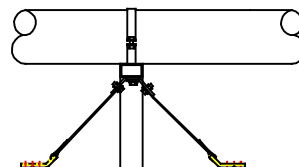

Axial Cable Restraints (Non-isolated)

RESTRAINED PIPE

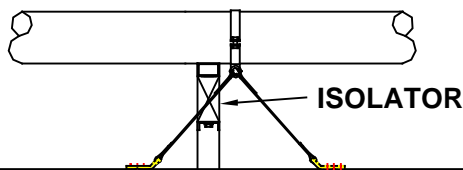

RESTRAINED SUPPORT

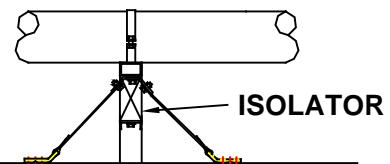

Axial Cable Restraints (Isolated)

FLOOR- OR ROOF-SUPPORTED PIPE RESTRAINT ARRANGEMENTS

Floor- or Roof-Mounted Systems Restrained with Struts

As with cable restraints, floor- or roof-mounted pipe support systems will normally involve a box frame that supports the piping (single or multiple) with some kind of a trapeze bar.

Lateral Restraint Examples

With struts there are three typical configurations. As with the cable systems, these arrangements can be used with or without isolation as shown below.

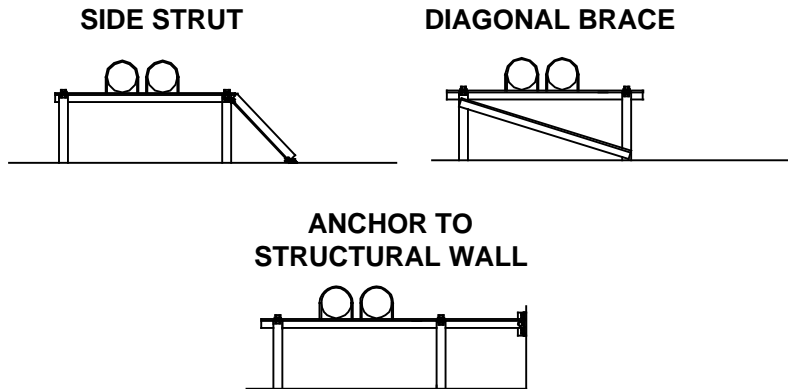

Typical Lateral Restraint Strut Arrangements for Piping (Non-isolated)

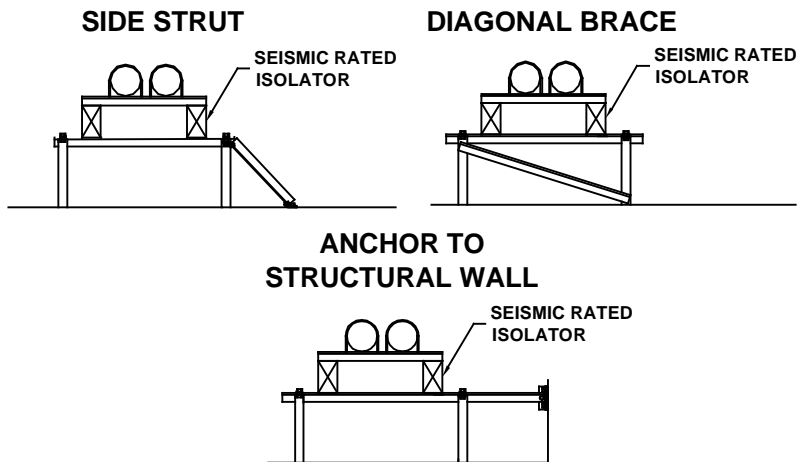

Typical Lateral Restraint Strut Arrangements for Piping (Isolated)

Axial Restraint Examples

When axially restraining piping, a trapeze or riser clamp tightly clamped to the pipe is the most common connecting device between the restraint strut and the pipe, but occasionally

FLOOR- OR ROOF-SUPPORTED PIPE RESTRAINT ARRANGEMENTS

PAGE 5 OF 6

RELEASE DATE: 1/6/04



Toll Free (USA only): 800-959-1229
International: 614-889-0480
Fax: 614-889-0540
World Wide Web: www.kineticsnoise.com
Email: sales@kineticsnoise.com

DOCUMENT:

D7.4.3



a weld-on tab or connection to a flange can be used. Details on these connections will be addressed in later sections.

Ignoring the details of the connection at this point, common axial restraint arrangements recognized in this manual are illustrated below.

As with the cable restraints, it must be recognized that axial restraints offset from the restrained pipe will generate additional bending forces in the pipe. This is true whether mounted to one end of a trapeze or along side a single pipe rather than directly under its center. When the restraint is offset, the maximum permissible offset from the center of the pipe is 1 pipe diameter. For trapezoid systems supporting multiple pipes, a single axial restraint should be located at the approximate center of the trapeze bar or pairs of axial restraints should be installed on each end of the trapeze bar or support frame.

**RESTRAINED
PIPE**

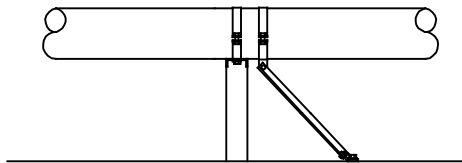

**RESTRAINED
SUPPORT**

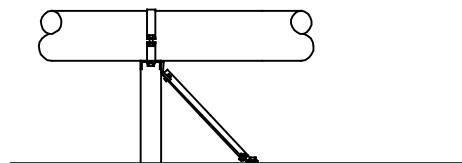

Piping Axially Restrained with Struts (Non-isolated)

**RESTRAINED
SUPPORT**

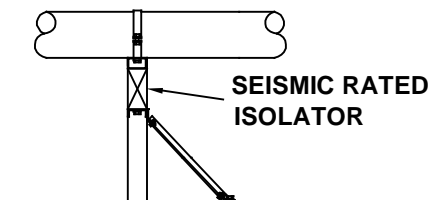

Piping Axially Restrained with Struts (Isolated)

FLOOR- OR ROOF-SUPPORTED PIPE RESTRAINT ARRANGEMENTS



DUBLIN, OHIO, USA • MISSISSAUGA, ONTARIO, CANADA

Toll Free (USA only): 800-959-1229
 International: 614-889-0480
 Fax: 614-889-0540
 World Wide Web: www.kineticsnoise.com
 Email: sales@kineticsnoise.com

DOCUMENT:
D7.4.3
 VISCMA
 MEMBER