

KHRC-A Rod Stiffener Data for $45^\circ < A \leq 60^\circ$

Introduction:

This document will aid the designer in determining if hanger rod reinforcement, rod stiffeners, will be required for a given application. If they are required, recommendations for a minimum stiffener size will be made. Also, rod stiffener clamp locations and spacing will be made based on the use of **Kinetics Noise Control** model **KHRC-A** Adjustable Angle Stiffener Kit. This kit is a single clamp system that is shown in Figure A8.3.1-1. One kit will be required for each clamp location. A minimum of two clamp kits will be required for each hanger rod stiffener. The clamps and rod stiffener are assembled to the hanger rod as shown in Figure A8.3.1-2. The dimensions shown as L_1 , L_2 , and L_3 are the maximum allowable installation dimensions for locating and spacing the **KHRC-A** clamp kits.

Buckling Analysis:

Buckling failure is a catastrophic form of failure that occurs at stresses that are much lower than those required to yield the material. It is more of a function of the geometry of the components than it is a function of the material. In general it is very difficult to predict the onset of buckling. Thus, the approach used in this document will of necessity be very conservative. All of the basic assumptions described below will lead to a conservative result.

There are many theories that address buckling. In general there are long, intermediate, and short columns. For long columns, Euler's formula is most often used with good results. For intermediate and short columns, there are many different approaches that would result in many iterative calculations for each case to be investigated. In order to provide reliable results with reasonable time expenditures, Euler's formula was used to determine the maximum un-reinforced hanger rod length. The hanger rods were modeled as having one end free, and one end fixed. If reinforcement was required for the hanger rod, it was selected based on the assumptions that the reinforcing angle was carrying the entire compressive load, and that the reinforcing angle was equal to the length of the hanger rod.

In a similar fashion, Euler's formula was used to determine the maximum allowable values for the clamp locating dimensions L_1 and L_3 . However, in this case L_1 and L_3 assumed to be equal to each other, and their sum was set to be equal to the maximum un-reinforced length of the hanger rod computed using Euler's formula with one end of the rod fixed and the other end free. In determining the maximum value for the clamp spacing, L_2 , Euler's formula was used assuming that both ends of the hanger rod were fixed at the clamps.

The horizontal seismic loads applied to the hanger rods are based on the **Kinetics Noise Control Horizontal Force Class**, or **Force Class**, designations of **I** through **VI**. The

KHRC-A ROD STIFFENER DATA FOR $45^\circ < A \leq 60^\circ$ - GENERAL

PAGE 1 OF 10

RELEASE DATE: 10/12/05



DUBLIN, OHIO, USA • MISSISSAUGA, ONTARIO, CANADA

Toll Free (USA only): 800-959-1229
International: 614-889-0480
Fax: 614-889-0540
World Wide Web: www.kineticsnoise.com
Email: sales@kineticsnoise.com

DOCUMENT:

A8.3.1



installation angle (**A**), as measured from the horizontal, was taken to be **60°**, and will be used to cover the range of installation angles from **46°** to **60°** inclusively. The Force Class system ranges are shown below.

- Force Class I: 0 lbs through 250 lbs**
- Force Class II: 251 lbs through 500 lbs**
- Force Class III: 501 lbs through 1,000 lbs**
- Force Class IV: 1,001 lbs through 2,000 lbs**
- Force Class V: 2,001 lbs through 5,000lbs**
- Force Class VI: 5,001 lbs through 10,000lbs**

The maximum load in each **Force Class** was used with a **Factor of Safety** of **2:1** in determining the maximum un-reinforced hanger rod length, the minimum angle size to be used for the rod stiffener, and the values used for **L₁**, **L₂**, and **L₃**.

Use of the KHRC-A Rod Stiffener Data Tables:

- 1.) **Data Tables:** There is a hanger rod stiffener selection data table for each **Force Class**.
- 2.) **Hanger Rod Sizes:** The hanger rod sizes that may be used with the **Kinetics Noise Control** model **KHRC-A**, and that are applicable for each **Force Class** are listed across the top of each data table.
- 3.) **Hanger Rod Length:** The hanger rod lengths that are applicable are listed in the left hand column of each table in **6"** and **12"** multiples. The maximum reinforced hanger rod length for each **Force Class** is the last entry in this column.
- 4.) **Rod Stiffener Requirement:** Determine the appropriate **Force Class** for the application. Select the column for the hanger rod size being used, and follow it down to the hanger rod length being considered. If the word **"Yes"** is found in this box, a hanger rod stiffener will be required. If, on the other hand, the word **"No"** is found in the box, then a hanger rod stiffener is not required. If the hanger rod length being used falls in between two of the tabulated rod lengths, use the larger value for the hanger rod length.
- 5.) **Minimum Stiffener Angle Size:** The minimum reinforcement angle size for each hanger rod length in each **Force Class** is listed in the right hand column of each table. Use the minimum Stiffener Angle size that corresponds to the hanger rod length used in step "4.)".
- 6.) **Maximum Installation Dimensions:** The maximum allowable installation dimensions, **L₁**, **L₂**, and **L₃**, are tabulated by hanger rod size beneath the rod stiffener selection data table for each **Force Class**.
- 7.) **KHRC-A Clamp Kits:** A minimum of two (2) **Kinetics Noise Control** model **KHRC-A** clamps kits are required for each hanger rod stiffener installation. The **KHRC-A** clamp kits should be spaced approximately **1"** from each end of the rod stiffener angle. The distance from where the hanger rod is attached to the suspended component and the lower **KHRC-A** clamp kit must not exceed the value for **L₁** listed for the **Force Class** and hanger rod size being used. If the spacing

KHRC-A ROD STIFFENER DATA FOR 45° < A ≤ 60° - GENERAL

PAGE 2 OF 10

RELEASE DATE: 10/12/05



Toll Free (USA only): 800-959-1229
International: 614-889-0480
Fax: 614-889-0540
World Wide Web: www.kineticsnoise.com
Email: sales@kineticsnoise.com

DOCUMENT:
A8.3.1
 VISCMA MEMBER

between the two **KHRC-A** clamp kits exceeds the value of L_2 , maximum allowable spacing between clamps, listed for the Force Class and rod size for the application, another **KHRC-A** clamp kit must be added between the original pair. Finally, the distance from the upper **KHRC-A** clamp kit where the hanger rod attaches to the structure, or isolation hanger, must not exceed the value listed for L_3 , based on the **Force Class** and rod size being considered. Also note that the thumb screw should be securely tightened. Pliers may be used after thumb screw is made finger tight.

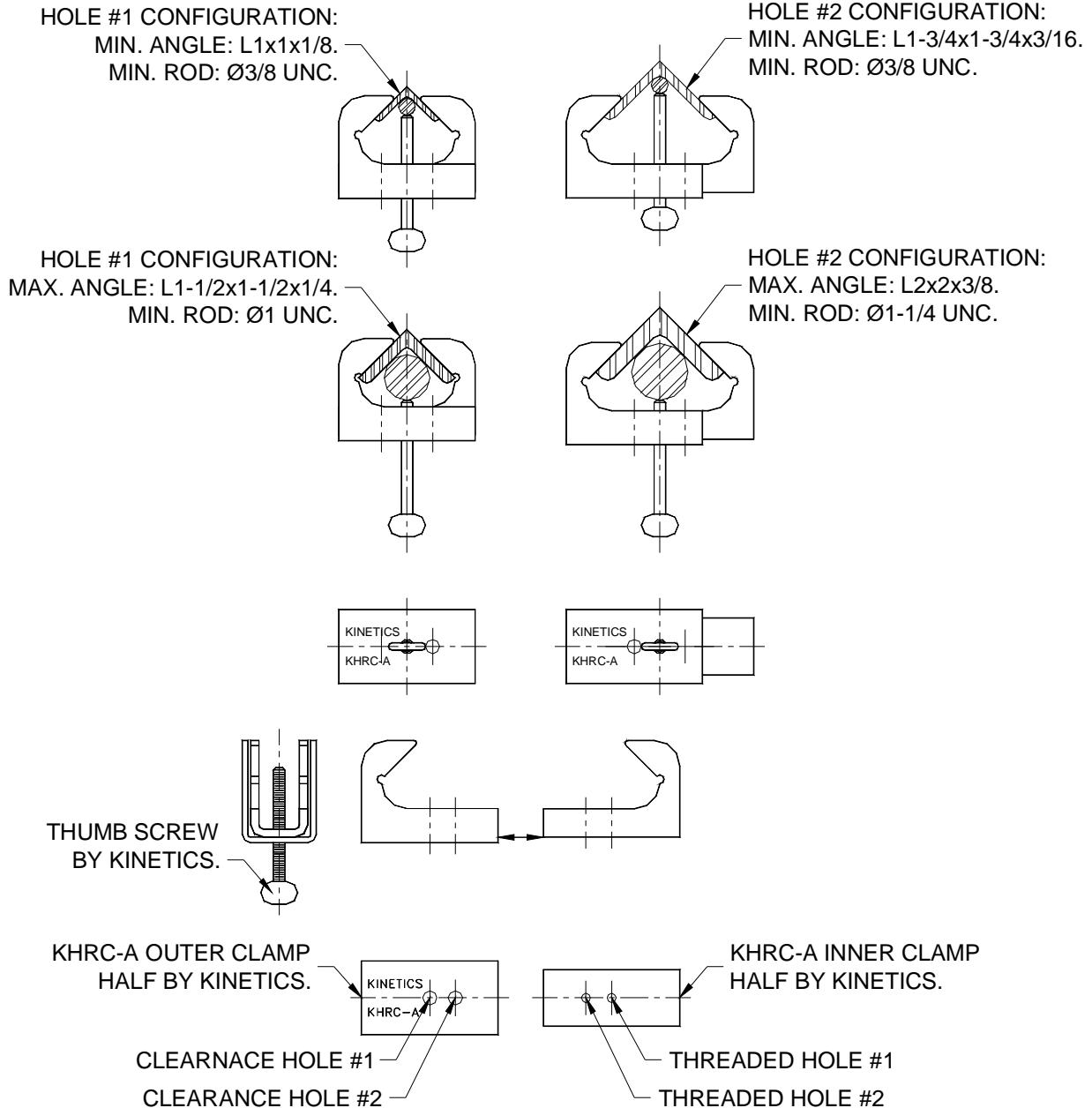

Figure A8.3.1-1; Kinetics Noise Control Model KHRC-A.

KHRC-A ROD STIFFENER DATA FOR 45° < A ≤ 60° - GENERAL



Toll Free (USA only): 800-959-1229
 International: 614-889-0480
 Fax: 614-889-0540
 World Wide Web: www.kineticsnoise.com
 Email: sales@kineticsnoise.com

DOCUMENT:
A8.3.1
 VISCMA
 MEMBER

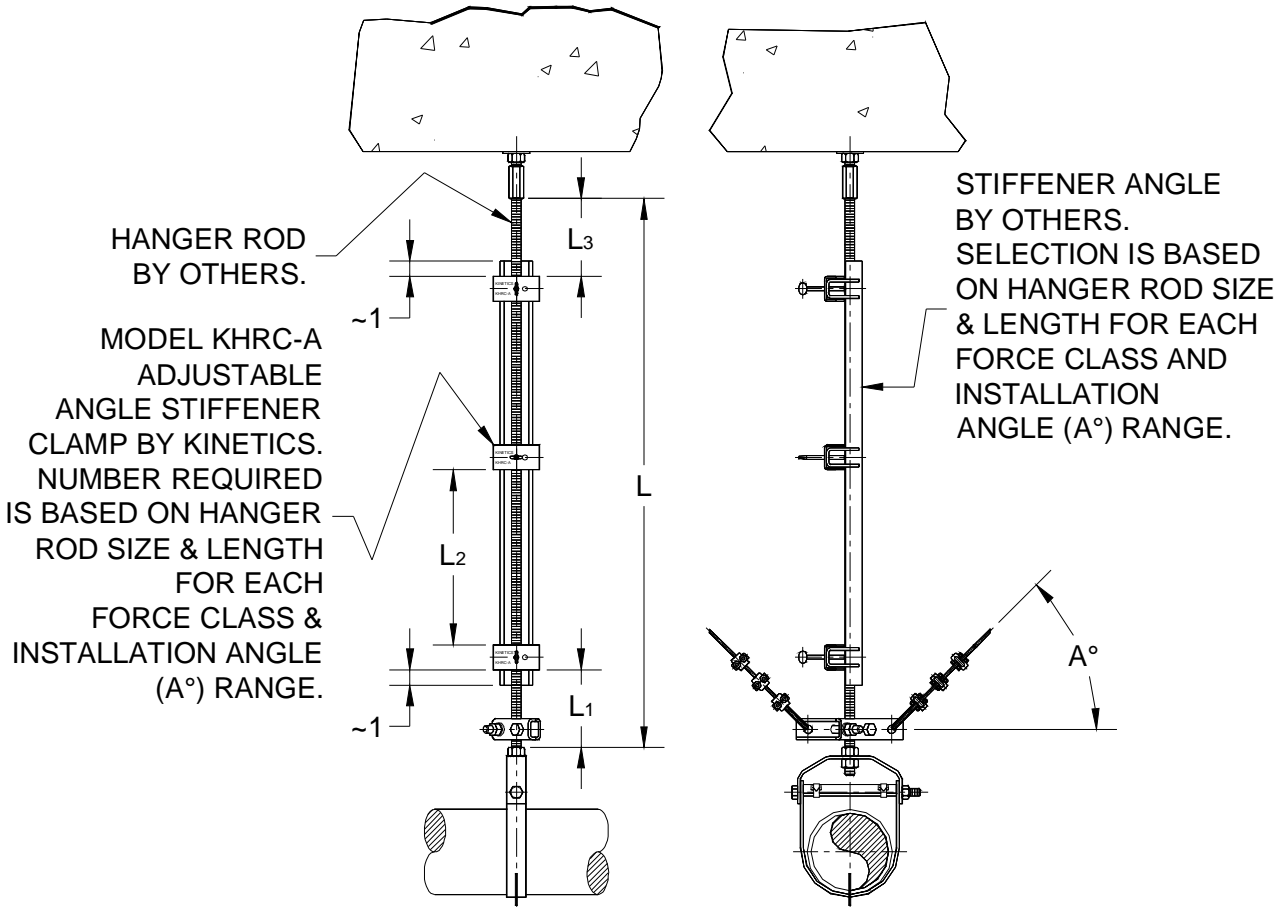

Figure A8.3.1-2; Typical Hanger Rod Stiffener Installation.

KHRC-A ROD STIFFENER DATA FOR $45^\circ < A \leq 60^\circ$ - GENERAL



Toll Free (USA only): 800-959-1229
 International: 614-889-0480
 Fax: 614-889-0540
 World Wide Web: www.kineticsnoise.com
 Email: sales@kineticsnoise.com

DOCUMENT:
A8.3.1
 VISCMA
 MEMBER

Rod Length (")	3/8" Rod	1/2" Rod	5/8" Rod	3/4" Rod	7/8" Rod	1" Rod	1-1/4" Rod	Minimum Rod Stiffener Angle
6	Yes	No	No	No	No	No	No	1 x 1 x 1/8
12	Yes	Yes	No	No	No	No	No	1 x 1 x 1/8
18	Yes	Yes	Yes	No	No	No	No	1 x 1 x 1/8
24	Yes	Yes	Yes	No	No	No	No	1 x 1 x 1/8
30	Yes	Yes	Yes	Yes	No	No	No	1-1/8 x 1-1/8 x 1/8
36	Yes	Yes	Yes	Yes	Yes	No	No	1-1/4 x 1-1/4 x 3/16
42	Yes	Yes	Yes	Yes	Yes	No	No	1-1/4 x 1-1/4 x 3/16
48	Yes	Yes	Yes	Yes	Yes	Yes	No	1-1/4 x 1-1/4 x 1/4
54	Yes	Yes	Yes	Yes	Yes	Yes	No	1-1/2 x 1-1/2 x 3/16
60	Yes	Yes	Yes	Yes	Yes	Yes	No	1-1/2 x 1-1/2 x 3/16
66	Yes	Yes	Yes	Yes	Yes	Yes	No	1-1/2 x 1-1/2 x 1/4
72	Yes	Yes	Yes	Yes	Yes	Yes	No	1-3/4 x 1-3/4 x 3/16
78	Yes	Yes	Yes	Yes	Yes	Yes	Yes	1-3/4 x 1-3/4 x 3/16
84	Yes	Yes	Yes	Yes	Yes	Yes	Yes	1-3/4 x 1-3/4 x 1/4
90	Yes	Yes	Yes	Yes	Yes	Yes	Yes	2 x 2 x 3/16
96	Yes	Yes	Yes	Yes	Yes	Yes	Yes	2 x 2 x 3/16
102	Yes	Yes	Yes	Yes	Yes	Yes	Yes	2 x 2 x 1/4
108	Yes	Yes	Yes	Yes	Yes	Yes	Yes	2 x 2 x 1/4
114	Yes	Yes	Yes	Yes	Yes	Yes	Yes	2 x 2 x 5/16
120	Yes	Yes	Yes	Yes	Yes	Yes	Yes	2 x 2 x 5/16
126	Yes	Yes	Yes	Yes	Yes	Yes	Yes	2 x 2 x 3/8
132 Max.	Yes	Yes	Yes	Yes	Yes	Yes	Yes	2 x 2 x 3/8
Mounting Dim. (")	3/8" ROD	1/2" ROD	5/8" ROD	3/4" ROD	7/8" ROD	1" ROD	1-1/4" ROD	
Max. L ₁ =	2	4	7	12	16	22	36	
Max. L ₂ =	9	19	31	48	67	89	89	
Max. L ₃ =	2	4	7	12	16	22	36	

KHRC-A ROD STIFFENER DATA FOR 45° < A ≤ 60° - FORCE CLASS I



Toll Free (USA only): 800-959-1229
 International: 614-889-0480
 Fax: 614-889-0540
 World Wide Web: www.kineticsnoise.com
 Email: sales@kineticsnoise.com

DOCUMENT:
A8.3.1
 VISCMA MEMBER

Rod Length (")	3/8" Rod	1/2" Rod	5/8" Rod	3/4" Rod	7/8" Rod	1" Rod	1-1/4" Rod	Minimum Rod Stiffener Angle
6	Yes	No	No	No	No	No	No	1 x 1 x 1/8
12	Yes	Yes	Yes	No	No	No	No	1 x 1 x 1/8
18	Yes	Yes	Yes	Yes	No	No	No	1 x 1 x 1/8
24	Yes	Yes	Yes	Yes	No	No	No	1-1/4 x 1-1/4 x 3/16
30	Yes	Yes	Yes	Yes	Yes	No	No	1-1/4 x 1-1/4 x 3/16
36	Yes	Yes	Yes	Yes	Yes	Yes	No	1-1/4 x 1-1/4 x 1/4
42	Yes	Yes	Yes	Yes	Yes	Yes	No	1-1/2 x 1-1/2 x 3/16
48	Yes	Yes	Yes	Yes	Yes	Yes	No	1-1/2 x 1-1/2 x 1/4
54	Yes	Yes	Yes	Yes	Yes	Yes	Yes	1-3/4 x 1-3/4 x 3/16
60	Yes	Yes	Yes	Yes	Yes	Yes	Yes	1-3/4 x 1-3/4 x 1/4
66	Yes	Yes	Yes	Yes	Yes	Yes	Yes	2 x 2 x 3/16
72	Yes	Yes	Yes	Yes	Yes	Yes	Yes	2 x 2 x 1/4
78	Yes	Yes	Yes	Yes	Yes	Yes	Yes	2 x 2 x 1/4
84	Yes	Yes	Yes	Yes	Yes	Yes	Yes	2 x 2 x 5/16
90	Yes	Yes	Yes	Yes	Yes	Yes	Yes	2 x 2 x 3/8
93 Max.	Yes	Yes	Yes	Yes	Yes	Yes	Yes	2 x 2 x 3/8
Mounting Dim. (")	3/8" ROD	1/2" ROD	5/8" ROD	3/4" ROD	7/8" ROD	1" ROD	1-1/4" ROD	
Max. L ₁ =	1	3	5	8	11	15	25	
Max. L ₂ =	6	13	21	33	47	62	62	
Max. L ₃ =	1	3	5	8	11	15	25	

KHRC-A ROD STIFFENER DATA FOR 45° < A ≤ 60° - FORCE CLASS II



Toll Free (USA only): 800-959-1229
 International: 614-889-0480
 Fax: 614-889-0540
 World Wide Web: www.kineticsnoise.com
 Email: sales@kineticsnoise.com

DOCUMENT:
A8.3.1
 VISCMA MEMBER

Rod Length ("")	1/2" Rod	5/8" Rod	3/4" Rod	7/8" Rod	1" Rod	1-1/4" Rod	Minimum Rod Stiffener Angle
6	Yes	No	No	No	No	No	1 x 1 x 1/8
12	Yes	Yes	No	No	No	No	1 x 1 x 1/8
18	Yes	Yes	Yes	Yes	No	No	1-1/4 x 1-1/4 x 3/16
24	Yes	Yes	Yes	Yes	Yes	No	1-1/4 x 1-1/4 x 1/4
30	Yes	Yes	Yes	Yes	Yes	No	1-1/2 x 1-1/2 x 3/16
36	Yes	Yes	Yes	Yes	Yes	No	1-3/4 x 1-3/4 x 3/16
42	Yes	Yes	Yes	Yes	Yes	Yes	1-3/4 x 1-3/4 x 1/4
48	Yes	Yes	Yes	Yes	Yes	Yes	2 x 2 x 3/16
54	Yes	Yes	Yes	Yes	Yes	Yes	2 x 2 x 1/4
60	Yes	Yes	Yes	Yes	Yes	Yes	2 x 2 x 5/16
66 Max.	Yes	Yes	Yes	Yes	Yes	Yes	2 x 2 x 3/8
Mounting Dim. ("")	1/2" ROD	5/8" ROD	3/4" ROD	7/8" ROD	1" ROD	1-1/4" ROD	
Max. L ₁ =	2	3	5	8	10	17	
Max. L ₂ =	8	15	23	32	43	43	
Max. L ₃ =	2	3	5	8	10	17	

KHRC-A ROD STIFFENER DATA FOR 45° < A ≤ 60° - FORCE CLASS III



Toll Free (USA only): 800-959-1229
 International: 614-889-0480
 Fax: 614-889-0540
 World Wide Web: www.kineticsnoise.com
 Email: sales@kineticsnoise.com

DOCUMENT:
A8.3.1
 VISCMA MEMBER

Rod Length (")	1/2" Rod	5/8" Rod	3/4" Rod	7/8" Rod	1" Rod	1-1/4" Rod	Minimum Rod Stiffener Angle
6	Yes	Yes	No	No	No	No	1 x 1 x 1/8
12	Yes	Yes	Yes	No	No	No	1-1/4 x 1-1/4 x 3/16
18	Yes	Yes	Yes	Yes	Yes	No	1-1/4 x 1-1/4 x 1/4
24	Yes	Yes	Yes	Yes	Yes	No	1-1/2 x 1-1/2 x 1/4
30	Yes	Yes	Yes	Yes	Yes	Yes	1-3/4 x 1-3/4 x 1/4
36	Yes	Yes	Yes	Yes	Yes	Yes	2 x 2 x 1/4
42	Yes	Yes	Yes	Yes	Yes	Yes	2 x 2 x 5/16
46 Max.	Yes	Yes	Yes	Yes	Yes	Yes	2 x 2 x 3/8
Mounting Dim. (")	1/2" ROD	5/8" ROD	3/4" ROD	7/8" ROD	1" ROD	1-1/4" ROD	
Max. L ₁ =	1	2	3	5	7	12	
Max. L ₂ =	5	10	15	22	30	50	
Max. L ₃ =	1	2	3	5	7	12	

KHRC-A ROD STIFFENER DATA FOR 45° < A ≤ 60° - FORCE CLASS IV



Toll Free (USA only): 800-959-1229
 International: 614-889-0480
 Fax: 614-889-0540
 World Wide Web: www.kineticsnoise.com
 Email: sales@kineticsnoise.com

DOCUMENT:
A8.3.1
 VISCMA
 MEMBER

Rod Length (")	5/8" Rod	3/4" Rod	7/8" Rod	1" Rod	1-1/4" Rod	Minimum Rod Stiffener Angle
6	Yes	Yes	No	No	No	1 x 1 x 1/8
12	Yes	Yes	Yes	Yes	No	1-1/2 x 1-1/2 x 3/16
18	Yes	Yes	Yes	Yes	Yes	2 x 2 x 1/8
24	Yes	Yes	Yes	Yes	Yes	2 x 2 x 1/4
29 Max.	Yes	Yes	Yes	Yes	Yes	2 x 2 x 3/8
Mounting Dim. (")	5/8" ROD	3/4" ROD	7/8" ROD	1" ROD	1-1/4" ROD	
Max. L ₁ =	1	2	3	4	7	
Max. L ₂ =	5	9	13	18	18	
Max. L ₃ =	1	2	3	4	7	

KHRC-A ROD STIFFENER DATA FOR 45° < A ≤ 60° - FORCE CLASS V



Toll Free (USA only): 800-959-1229
 International: 614-889-0480
 Fax: 614-889-0540
 World Wide Web: www.kineticsnoise.com
 Email: sales@kineticsnoise.com

DOCUMENT:
A8.3.1
 VISCMA
 MEMBER

Rod Length (")	3/4" Rod	7/8" Rod	1" Rod	1-1/4" Rod	Minimum Rod Stiffener Angle
6	Yes	Yes	No	No	1-1/4 x 1-1/4 x 3/16
12	Yes	Yes	Yes	Yes	1-3/4 x 1-3/4 x 3/16
18	Yes	Yes	Yes	Yes	2 x 2 x 5/16
20 Max.	Yes	Yes	Yes	Yes	2 x 2 x 3/8
Mounting Dim. (")	3/4" ROD	7/8" ROD	1" ROD	1-1/4" ROD	
Max. L ₁ =	1	2	3	5	
Max. L ₂ =	6	9	12	21	
Max. L ₃ =	1	2	3	5	

KHRC-A ROD STIFFENER DATA FOR 45° < A ≤ 60° - FORCE CLASS VI



Toll Free (USA only): 800-959-1229
 International: 614-889-0480
 Fax: 614-889-0540
 World Wide Web: www.kineticsnoise.com
 Email: sales@kineticsnoise.com

DOCUMENT:
A8.3.1
 VISCMA MEMBER